



# LL SERIES



HORIZONTAL TURNING & TURNMILL CENTERS

### CNC TURNING CENTERS

**2 Axes** Upto 700 mm turning length



LL20T L3/L5/L7, LL25T L5/L7/ LL30T L7

**2 Axes** One metre CNC Turning Centers



LL20T L10/LL25T L10/LL30T L10

### MACHINING SOLUTIONS

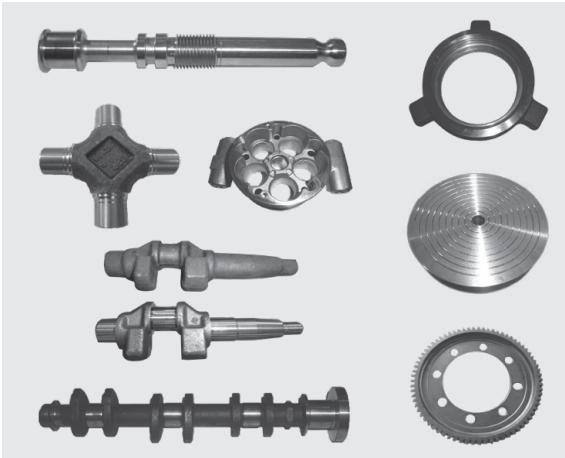

### TURNMILL CENTERS

**3 Axes** Live tool



LL20TM L5/L7/L10, LL25TM L7, LL30TM L10

**Upto 6 Axes** Live tool, Y axis, Sub-spindle



LL20MY L5, LL20MYS L5

### MACHINING SOLUTIONS



## LL30T L10



### HIGHLIGHTS

- Larger swing over bed.
- Bearing diameter of 120mm with A2-8 spindle nose.
- Bigger size rigid hydraulic turret with A/F 400mm.
- High Precision Roller LM Guide ways.
- Boring bar diameter of 50mm for bigger operations.
- Highly rigid bed structure for heavy cutting.
- User friendly design.

### MACHINING SOLUTIONS



## LL SERIES

LL Series, CNC lathes to stay ahead of your competition with high efficiency turning.

The LL Series capture all your needs to sustain from here. These are with additional power, faster traverses and indeed very user friendly.

Simple to use, easy to maintain, the LL Series is a true value to improve overall manufacturing efficiency.

The LL Series lends itself minimum floor space and available time.

Computer optimised cast iron (FG 300) box structure bed for stable material removal, free of vibration.

### LL20TL3 / L5 / L7 / L10

9 kW (continuous) power at the spindle provides enormous capacity for highly efficient metal cutting. A massive hydraulic turret providing over 23 kN of clamping force ensures very stable machining. Very responsive feed mechanism incorporating widely spaced, amply dimensioned Linear Motion guides and large diameter ball screws provide excellent part-to-part repeat accuracies.

Copious coolant and stability in machining ensure use of optimum cutting parameters, thereby reducing cost. Interference free turning diameter and ample working clearances are added for operator convenience.

### HYDRAULIC TURRET

The 8 station vertically indexing turret uses bi-directional shortest path indexing to reduce non-cut time. The forged steel turret employs a high torque hydraulic motor for indexing and clamping.

### OPTIONAL

12 station turret

25x25 square shank with maximum boring bar diameter of 40 mm Use of a 180mm diameter coupling and 23 kN of clamping force ensures very stable machining close to clamping forces.



### LL25TL5 / L7 / L10

The LL25T takes a 254 mm diameter chuck and yet provide ample working clearances as well as interference free tool setting. The maximum turning length available is 480, 670 & 1020 mm.

Full 15 kW from 292 rpm onwards through inbuilt motor Low gear / High gear winding connections switch over through M codes.

### LL30TL7 / L10

The LL30T takes a 304 mm diameter chuck that provides maximum turning diameter of 400 mm and maximum turning length of 611 & 960 mm which helps to cater the turning demand of today's and tomorrow's market.

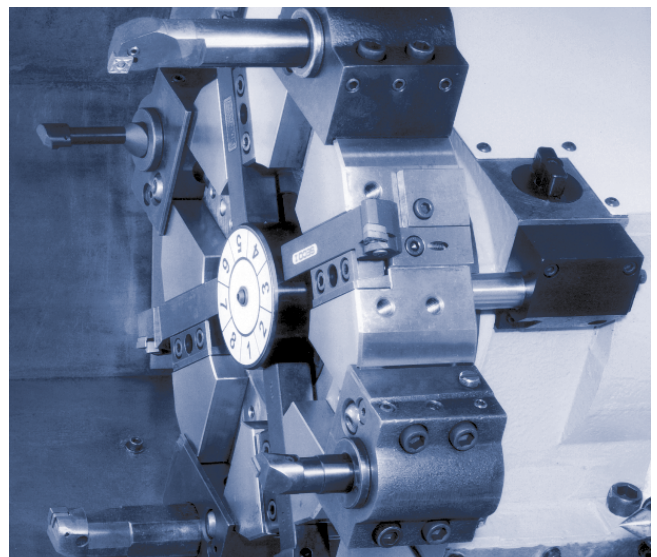

### HIGH RESPONSE FEED MECHANISM

The LL Series employs low-friction linear Motion guideways for both the axis traverses. The seating and locating surface are precision machined to a tolerance of 10 microns. The LM guides provide stick-slip free movement. These are extremely long lasting and free of any deformation, thereby retaining the accuracies over a longer period of continuous use.

Large diameter ball screws, with double nut pretensioning helps in providing ample feed thrust and high rapid traverse rate. The ball screw remain supported at both ends by P4 class angular contact ball bearings. The stiffness built into the feed mechanism of the LL Series ensures a high degree of accuracy in positioning as well as interpolated cutting. Excellent part to part repeat accuracies allow you to achieve greater process capabilities.

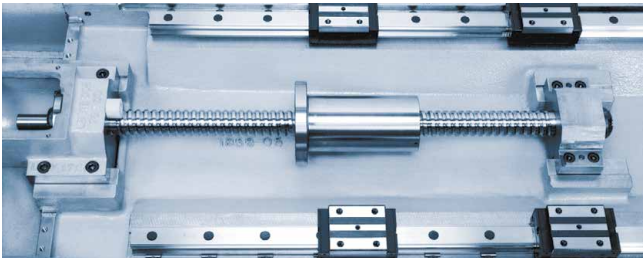

### UNIVERSAL APPLICATION

The LL series is equally suitable for both chucking & shaft turning applications.

The heavy duty tailstock interpolates an MT-5 ADD-ON center & provides a maximum thrust of 500 kg.

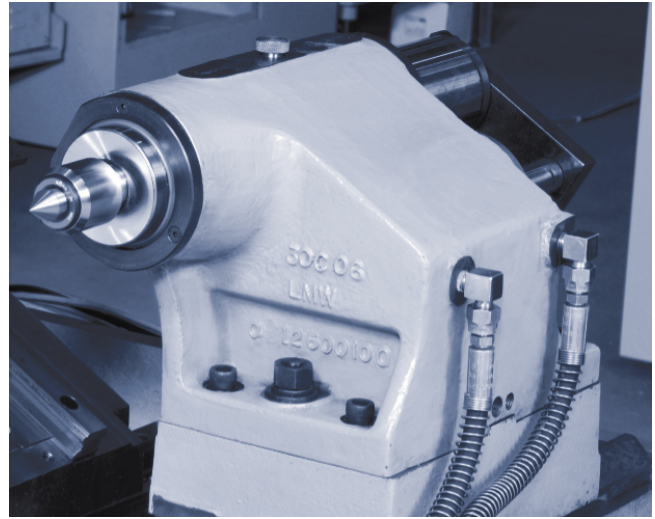

### MOVING RANGE LL20T L3 / L5 / L7 / L10 LL25T L5 / L7 / L10

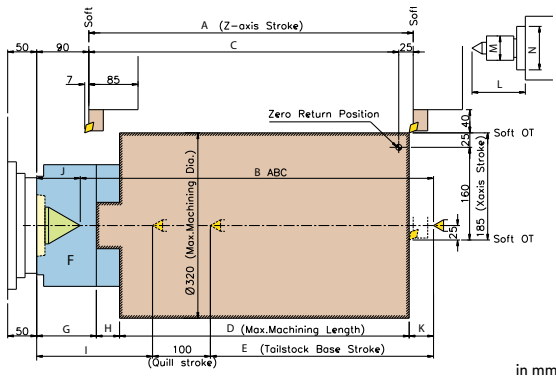

### LL30T L7 / L10

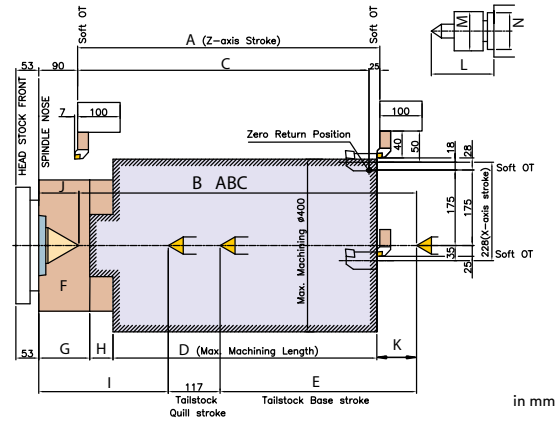

Description	LL20T L3	LL20T L5	LL20T L7	LL20T L10	LL25T L5	LL25T L7	LL25T L10	LL30T L7	LL30T L10
A	370	560	750	1100	560	750	1100	700	1050
B	440	625	830	1175	610	815	1160	782	1100
C	345	535	725	1075	535	725	1075	675	1025
D	310	500	690	1040	480	670	1020	611	960
E	235	420	575	920	420	575	920	458	876
*F	Ø210	Ø210	Ø210	Ø210	Ø254	Ø254	Ø254	Ø304	Ø304
*G	103	103	103	103	120	120	120	118	118
*H	40	40	40	40	43	43	43	54	54
I	180	180	230	230	180	230	230	300	200
J	75	75	75	75	90	90	90	93	93
K	62	57	72	67	57	72	67	92	61
L	120	120	120	120	142	142	142	147	147
M	Ø68	Ø68	Ø68	Ø68	Ø87	Ø87	Ø87	Ø87	Ø87
N	Ø75	Ø75	Ø75	Ø75	Ø85	Ø85	Ø85	Ø85	Ø85

\* Value varies w.r.t chuck manufacturer.

LL SERIES  
 BASIC INFORMATION  
 DIAGRAMS  
 SPECIFICATIONS  
 APPLICATIONS & SOLUTIONS

LL SERIES

BASIC INFORMATION

DIAGRAMS

SPECIFICATIONS

APPLICATIONS & SOLUTIONS

**TURRET INTERFERENCE**

**LL20T L3 / L5 / L7 / L10**

8 STATION

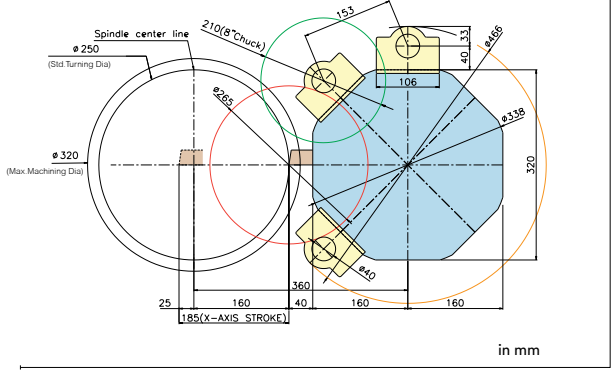

**LL25T L5 / L7 / L10**

8 STATION

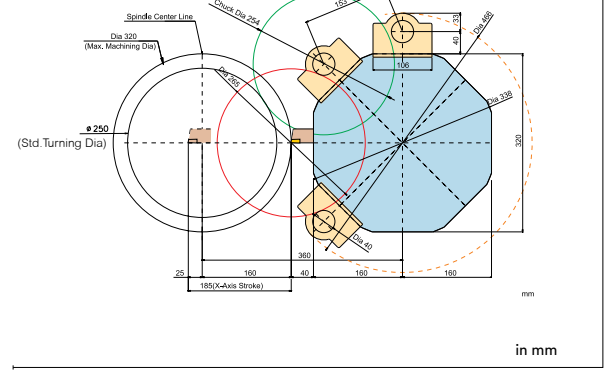

**LL30T L7 / L10**

8 STATION

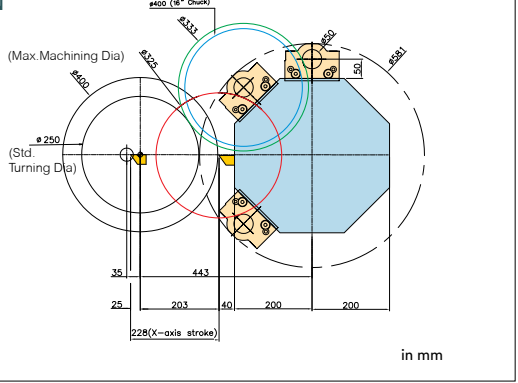

**LL20T L3 / L5 / L7 / L10 / LL25T L5 / L7 / L10**

12 STATION

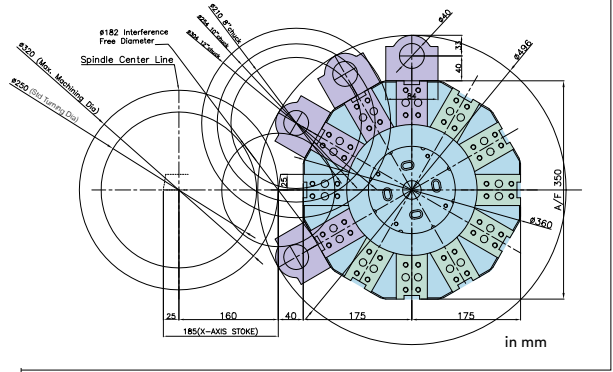

**SPEED POWER CURVE**

**LL20T L3 / L5 / L7 / L10**

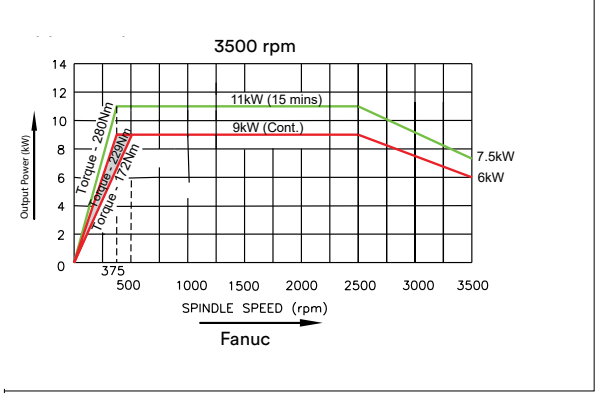

**LL25T L5 / L7 / L10**

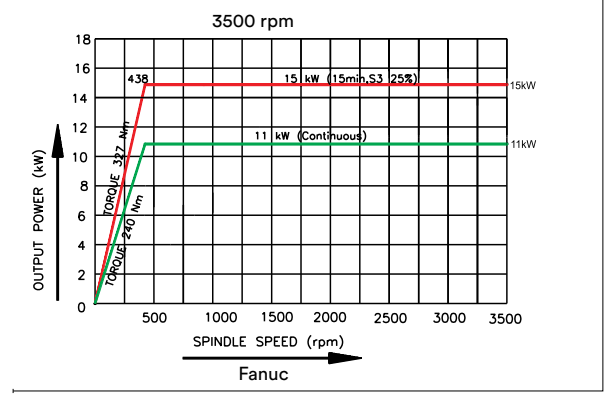

**LL30T L7 / L10**

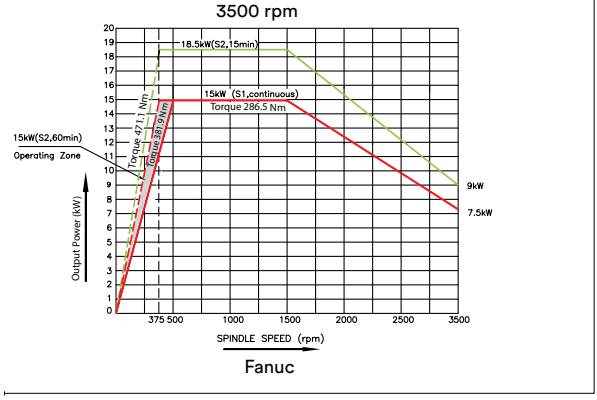

## SPECIFICATIONS

Title	Description	Unit	LL 20T L3	LL 20T L5	LL 20T L7	LL20T L10	LL 25T L5	LL 25T L7	LL25T L10	LL30T L7	LL30T L10	
Capacity	Swing over bed	mm	510								610	
	Chuck dia. Max	mm	210				254				304	
	Max. Turning dia	mm	320								400	
	Max. Turning Length*	mm	310	500	690	1040	480	670	1020	611	960	
	Admit between Centres	mm	440	625	830	1175	610	815	1160	782	1100	
Spindle	Spindle nose	type	A2-6								A2-8	
	Hole through spindle	mm	61				77					
	Spindle speed	rpm	3500								3000	
	Spindle motor power (Cont./15 Min)	kW	9/11				11 / 15				15/18.5	
Feed System	Cross travel X-axis	mm	185								228	
	Longitudinal travel Z-axis	mm	370	560	750	1100	560	750	1100	700	1050	
	Rapid traverse rate X/Z axes	m/min	30 / 36									
Turret	No. of stations	nos.	8									
	Tool shank size	mm	25 x 25									
	Max. Boring bar dia.	mm	40								50	
	Turret indexing	type	Bi-directional									
	Turret indexing time	sec	Less than 1								Less than 1.2	
Tailstock	Quill dia	mm	75				85					
	Quill stroke	mm	100								117	
	Quill taper	-	MT-4				MT-5					
CNC System	Controller	-	Fanuc / Siemens*									
Power Supply	Power Requirement	kVA	21				28.6				30	
Machine Size	Front x Side x height	mm	2065 x 1650 x 1920	2255 x 1650 x 1920	2705 x 1650 x 1920	3055 x 1695 x 1920	2505 x 1650 x 1920	2705 x 1650 x 1920	3055 x 1695 x 1920	2915 x 1810 x 2085	3230 x 1900 x 2085	
	Weight	Kg	3500	3500	3800	4200	3800	4000	4200	5000	5500	

Note: \*May vary depending upon make / model of chuck.

## MATERIAL REMOVAL RATE (MRR) STEEL EN8

### OUTER DIA TURN TEST

Description	Unit	LL20T Series	LL25T Series	LL30T Series	
				Min	Max
Diameter	mm	64	79	171	376
Cutting Speed	m/min	200	200	205	250
Spindle Speed	rpm	1000	806	380	212
DOC	mm	3	7.5	6.5	5
Feed	mm/rev	0.32	0.3	0.25	0.2
Capacity	cc/min	192	450	333	250
Spindle Load	%	100	100	82	108
Max.Spindle speed	rpm	3500	3500	3500	3500
Spindle Base speed	rpm	1000	438	500	500
Spindle Power	kW	9/11	11/15	15/18.5	15/18.5

### DRILLING TEST

Description	Unit	LL20T Series	LL25T Series	LL30T Series
Diameter	mm	40	50	50
Cutting Speed	m/min	150	150	125
Spindle Speed	rpm	1190	850	800
Feed	mm/rev	0.1	0.12	0.18
Spindle Load	%	100	100	70
Max.Spindle speed	rpm	3500	3500	3500
Spindle Base speed	rpm	1000	438	500
Spindle Power	kW	9/11	11/15	15/18.5

## ACCURACY

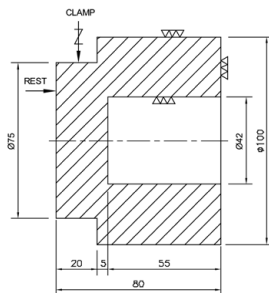

Surface Finish Ra			Roundness mm		Perpendicularity mm	
I.D.	O.D.	Face	I.D.	O.D.	I.D.	O.D.
0.3	0.3	0.24	0.002	0.002	0.002	0.002
Cylindricity mm		Concentricity mm	Flatness mm			
I.D.	O.D.					
0.003	0.003	0.004	0.002			

Material	Aluminium / Brass
Clamping Area	Ø75 x 20 mm
Clamping Pressure	10 Kgf/cm <sup>2</sup>
Tool Holder	SVJCR 2525M16
Insert	VCGx160404
Cutting Speed (Vc)	400 m/min
D.O.C	0.05 mm
Feed	0.05 mm/rev

## MATERIAL : STEEL EN8



### Tapping

	LL20T Series	LL25T Series	LL30T Series
Max. Tap Size	M16 x 2	M24 x 3	M30 x 3

### Threading

	Threading Dia	Cutting Speed	Spindle Speed	Pitch	Spindle Load
LL30T Series	170 mm	245 m/sec	400 rpm	4 tpi	24%



### Profile Turning

Sphericity	0.007 mm
------------	----------

Note : Values shown are in test conditions, may vary depending on tools, materials and cutting parameters / conditions

LL SERIES  
BASIC INFORMATION  
DIAGRAMS  
SPECIFICATIONS  
APPLICATIONS & SOLUTIONS

## TURNMILL CENTRES

- LL20TM L5
- LL20TM L7
- LL20TM L10
- LL25TM L7
- LL30TM L10

## LIVE TOOL TURRET

- 12 station driven tools
- BMT 55/65 Turret
- Clamping / Declamping - Hydraulic
- Turret Indexing - Servo Turret

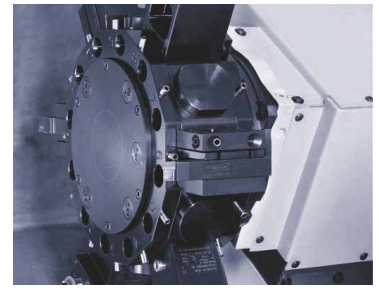

## MOVING RANGE

### LL20TM L5 / L7 / L10

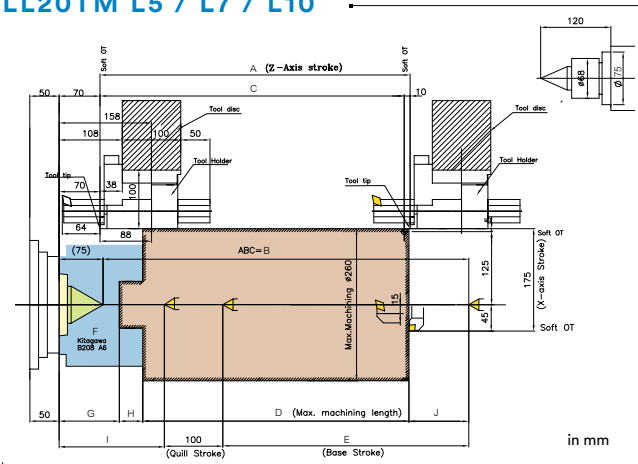

Description	A	B	C	D	E	F	G	H	I	J
LL20TM L5	530	625	520	455	420	Ø210	103	40	180	102
LL20TM L7	750	830	740	675	575	Ø210	103	40	230	87
LL20TM L10	1050	1175	1040	975	920	Ø210	103	40	230	132

### LL25TM L7

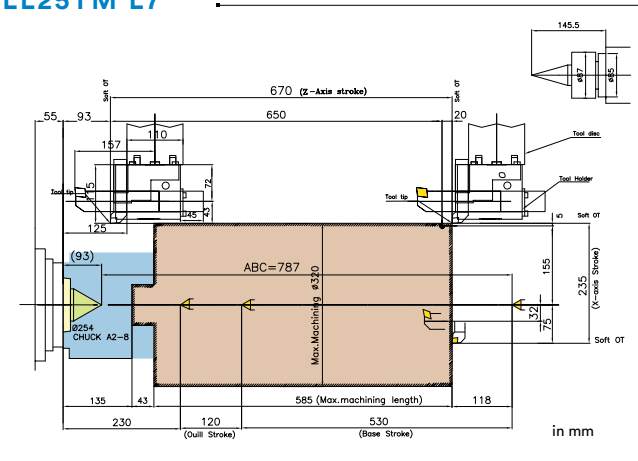

### LL30TM L10

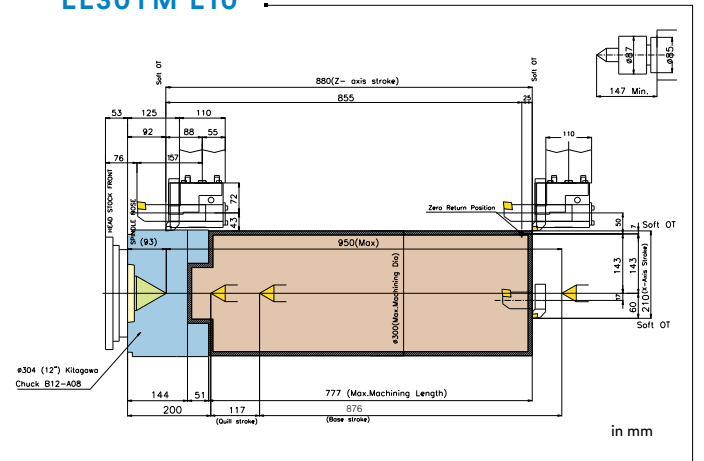

## TURRET INTERFERENCE

### LL20TM L5 / L7 / L10

12 STATION

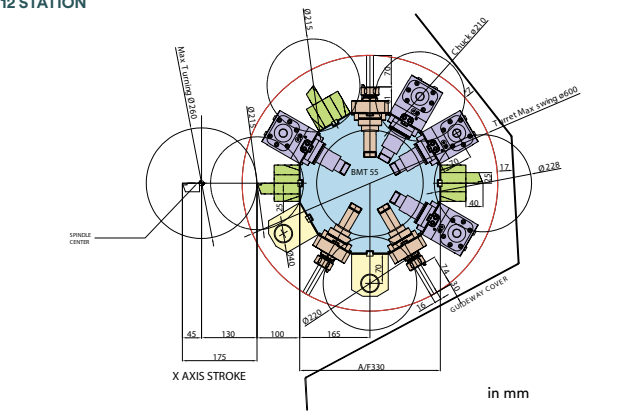

### LL25TM L7

12 STATION

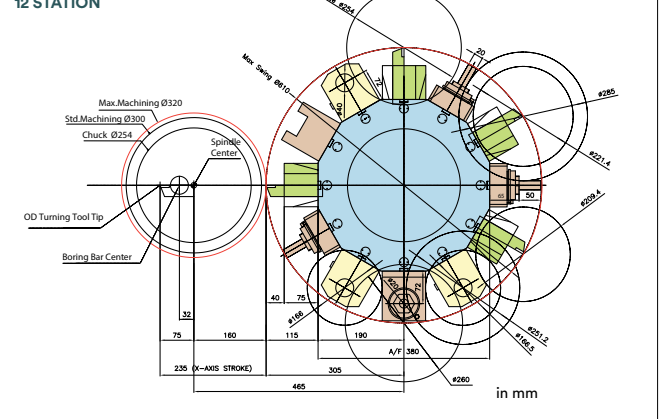

LL SERIES

BASIC INFORMATION

DIAGRAMS

SPECIFICATIONS & SOLUTIONS

**LL30TM L10**

12 STATION

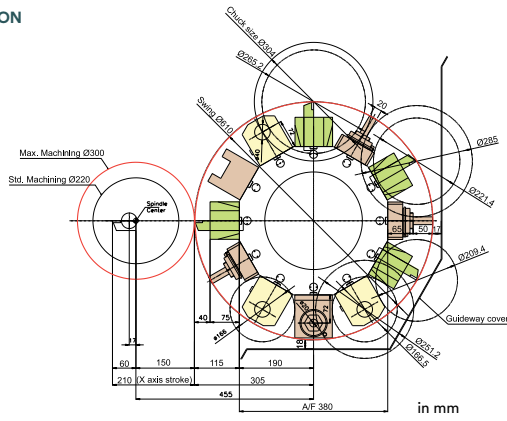

**SPEED POWER CURVE**

**LL20TM L5 / L7 / L10**

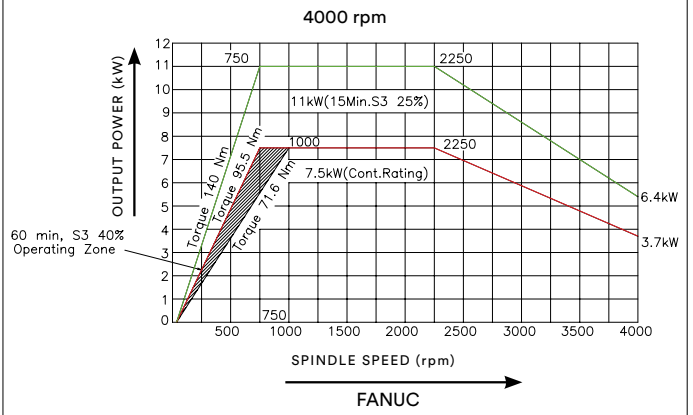

**LL25TM L7**

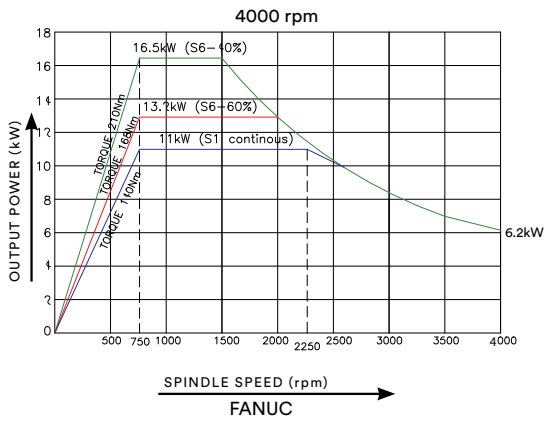

**LL30TM L10**

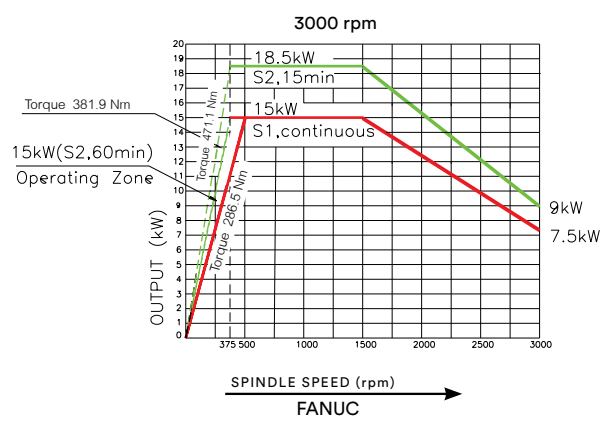

**SPECIFICATIONS**

Title	Description	Unit	LL20TM L5	LL20TM L7	LL20TM L10	LL25TM L7	LL30TM L10	
Capacity	Swing over bed	mm	510				610	
	Chuck dia, max	mm	210				254	304
	Max turning diameter	mm	260				320	300
	Max. turning length*	mm	455	675	975	585	777	
	Admit between centres	mm	625	830	1175	787	1100	
Spindle	Spindle nose	type	A2 - 6				A2 - 8	
	Hole through spindle	mm	61				77	
	Spindle speed	rpm	4000				3000	
	Spindle motor power (Cont./15min)	kW	7.5 / 11				11 / 15	15/18.5
Feed System	Cross travel X-axis	mm	175				220	210
	Longitudinal travel Z-axis	mm	530	750	1050	670	880	
	Rapid traverse rate X/Z-axes	m/min	30 / 36					
Turret	No. of stations	nos	12					
	Tool shank size	mm	25x25					
	Maximum boring bar dia	mm	40					
	Turret indexing	type	Servo					
Rotary	Spindle speed for rotary tool	rpm	5000					
	Motor power for rotary tool	kW	4.5					
Tailstock	Quill dia	mm	75				85	
	Quill stroke	mm	100				120	117
	Quill taper	-	MT-4				MT-5	
CNC System	Controller	-	Fanuc / Siemens*				Fanuc	
Power Supply	Power Requirement	kVA	25				30	35
Machine Size	Front x Side x height	mm	2465 x 1770 x 1920	2920 x 1770 x 1920	3270 x 1945 x 1920	2920 x 1820 x 2020	3230 x 1900 x 2085	
	Machine weight (Approx)	kg	4000	4200		4500	6000	

Note: \*May vary depending upon make / model of chuck.

BASIC INFORMATION  
DIAGRAMS  
SPECIFICATIONS & SOLUTIONS

## TURNMILL CENTRE WITH Y AXIS LL20MY L5



### TMC Vs. TMC with Y Axis

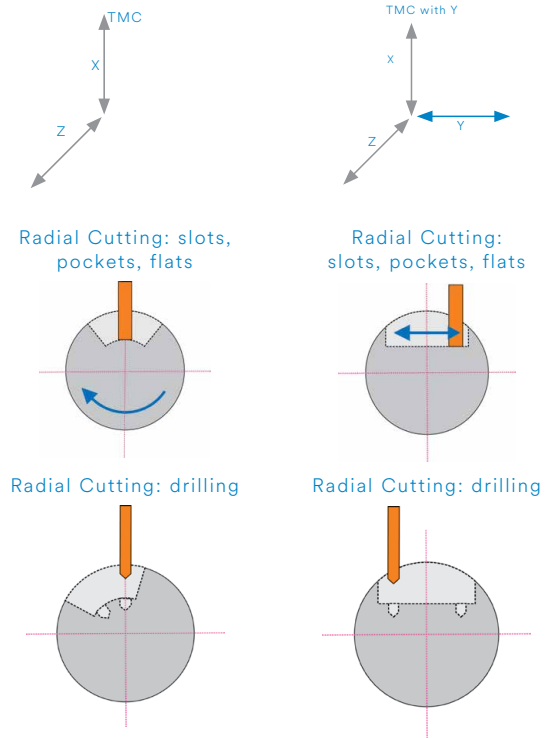

- 60° inclined, simplified design / structure
- LM Guides
- BMT 55 Turret
- 12 Station Drive Tools

### SPECIFICATIONS

Title	Description	Unit	LL20MY L5
Capacity	Swing over bed	mm	510
	Chuck dia. Max	mm	210
	Max. Turning dia	mm	300
	Max. Turning Length*	mm	414
	Admit between Centres	mm	625
Spindle	Spindle nose	type	A2-6
	Hole through spindle	mm	61
	Spindle speed	rpm	4000
	Spindle motor power(Cont./S6 40%)	kW	9 / 13.5
Feed System	Inclination Cross slide	deg	60° to horizontal plan
	Travel X-axis	mm	230
	Travel Y-axis	mm	±50
	Travel Z-axis	mm	520
	Rapid traverse rate X / Y/ Z axes	m/min	30 / 15 / 30
Live tool Turret	Turret Type	-	BMT 55
	No. of stations	nos.	12
	Tool shank size	mm	25 x 25
	Max. Boring bar dia.	mm	40
	Turret indexing	type	Servo
	Turret indexing time	sec	2.3 to 2.5
	Driven motor power	kW	4.82
Tailstock	Rotary tool speed	rpm	4500
	Quill dia	mm	75
	Quill stroke	mm	100
CNC System	Quill taper	-	MT-4
	Controller	-	Siemens
Power Supply	Power Requirement	kVA	35
Machine Size	Front x Side x height	mm	2940 x 1788 x 2005
	Weight	kgs	4500

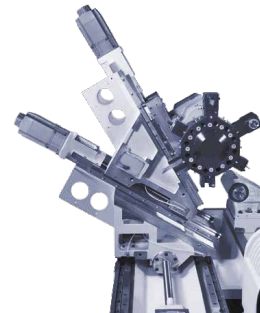
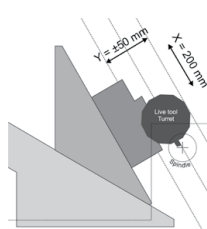

### MATERIAL REMOVAL RATE MATERIAL : STEEL EN8

Description	Unit	LL20MY L5
Work Piece Ø	mm	66
Cutting Speed	m/min	200
Spindle	rpm	965
Feed	mm/min	0.25
Depth of Cut	mm	4

Description	Unit	Radial		Axial		
		Y	Z	X	C	
Milling Cutter Ø	mm	15	16	15	16	16
Cutting Speed	m/min	30	30	30	30	30
Spindle	rpm	640	600	640	600	600
Feed	mm/min	130	120	130	120	120
Depth of Cut	mm	8	6	7	6	3

Description	Unit	LL20MY L5
Tap Ø	mm	M10X1.5
Cutting Speed	m/min	8
Spindle	rpm	250
Feed	mm/min	375
Depth of Cut	mm	12

Description	Unit	Solid Carbide	HSS Drill
Drill Ø	mm	10	14.5
Cutting Speed	m/min	60	30
Spindle	rpm	2000	660
Feed	mm/min	200	100
Pecking Depth	mm	10	5

\* Note : Values shown are in test conditions, may vary depending on tools, materials and cutting parameters / conditions

Note: \*May vary depending upon make / model of chuck.

LL SERIES

BASIC INFORMATION

DIAGRAMS

SPECIFICATIONS

APPLICATIONS & SOLUTIONS

### MOVING RANGE

#### LL20MY L5

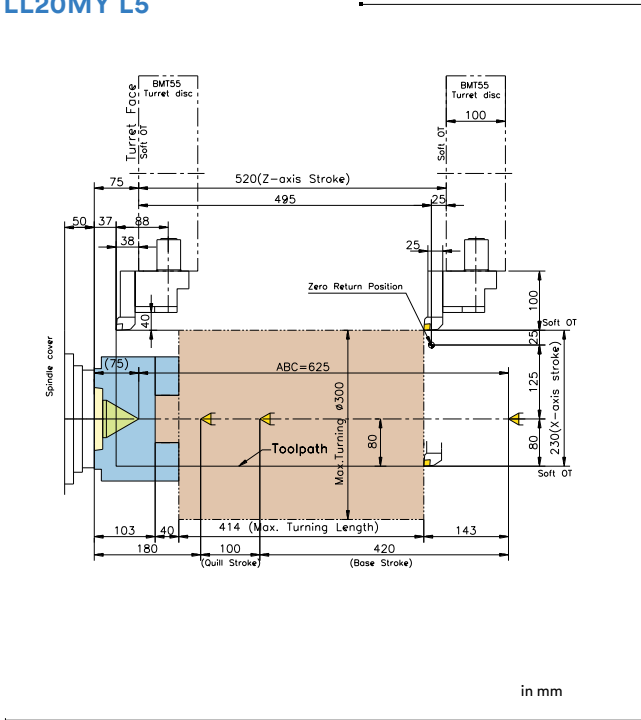

#### Y AXIS

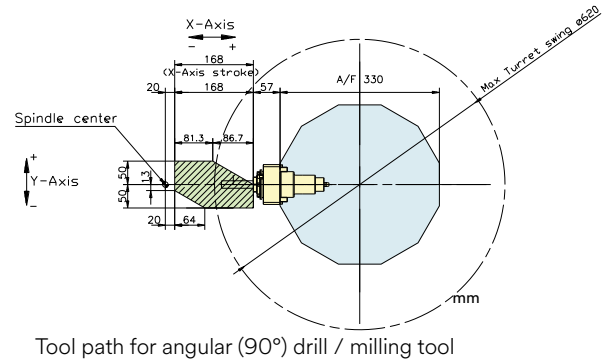

Note:  
Angular Tool Holder (90°) Center height CH = 85mm  
At Spindle Center + Y axis stroke = +50, - Y axis stroke = -37.3

#### Y AXIS

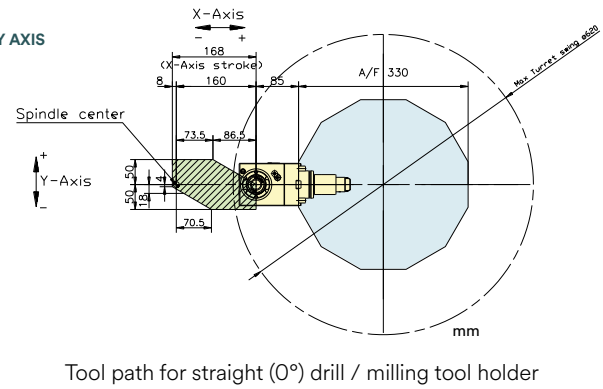

### TURRET INTERFERENCE

#### LL20MY L5

12 STATION

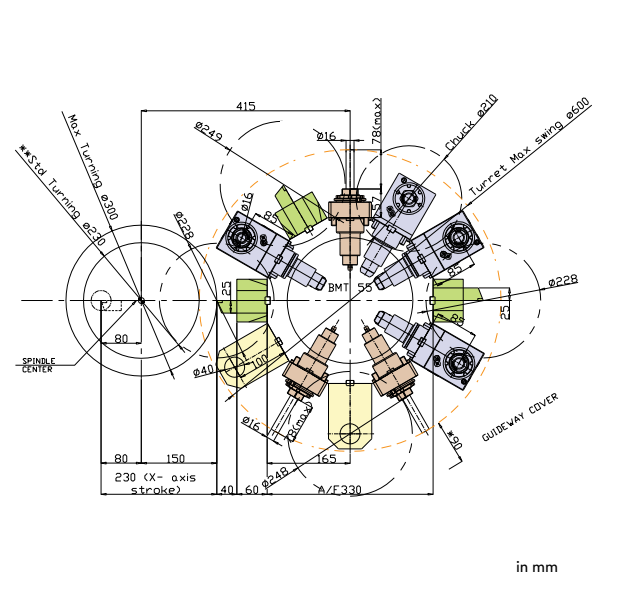

### SPEED POWER CURVE

#### LL20MY L5



LL SERIES

BASIC INFORMATION

DIAGRAMS

SPECIFICATIONS

APPLICATIONS & SOLUTIONS

## TURNMILL CENTRE WITH Y AXIS & SUB-SPINDLE LL20 MYS L5

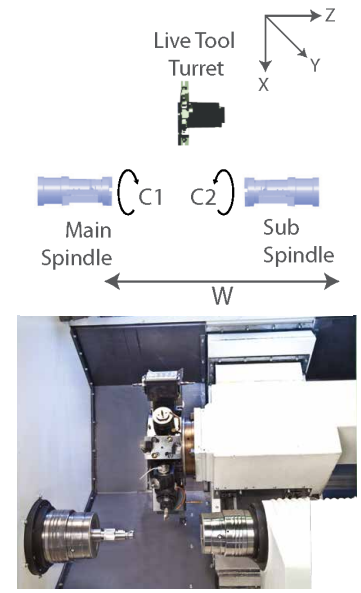

- 60° inclined, simplified design / structure
- LM Guides
- BMT 55 Turret
- 12 Station Drive Tools
- Sub Spindle

### SPECIFICATIONS

Title	Description	Unit	LL20MYS L5
Capacity	Swing over bed	mm	560
	Max. Turning dia	mm	290
	Max. Turning Length*	mm	470
	Admit between Centres	mm	613
Main Spindle	Spindle nose	type	A2-6
	Chuck dia.	mm	210
	Hole through spindle	mm	61
	Max. Spindle speed	rpm	4000
	Spindle motor power	kW	7.5 / 11
Sub Spindle	Spindle nose	type	A2-5
	Chuck dia.	mm	165
	Hole through spindle	mm	53
	Max. Spindle speed	rpm	5000
Spindle motor power		kW	5.5/ 7.5
	Inclination Cross slide	mm	60° to Horizontal Plane
Feed System	Travel X-axis	mm	173
	Travel Y-axis	mm	± 50
	Travel Z-axis	mm	576
	Travel W-axis	mm	525
	Rapid Traverse (X / Y / Z / W)		
Live tool Turret	Turret Type	-	BMT 55
	No. of stations	nos.	12
	Tool shank size	mm	25 x 25
	Max. Boring bar dia.	mm	40
	Turret indexing	type	Servo
	Turret indexing time	sec	1
Driven motor power	kW	4.5	
CNC System	Controller	-	Fanuc
Power Supply	Power Requirement	kVA	45
Machine Size	Front x Side x height	mm	3242 x 2085 x 2010
	Weight	kg	4800

### HIGHLIGHTS

- Turning Center with Y axis and Sub-Spindle.
- 60° inclined, simplified design/structure.
- Ball Screw Driven W axis on LM guides.
- High Accuracy Encoder for C - Axis (±10 arc Sec.)
- 12 Station Drive Tools, BMT 55 Turret.

### MOVING RANGE LL20MYS L5

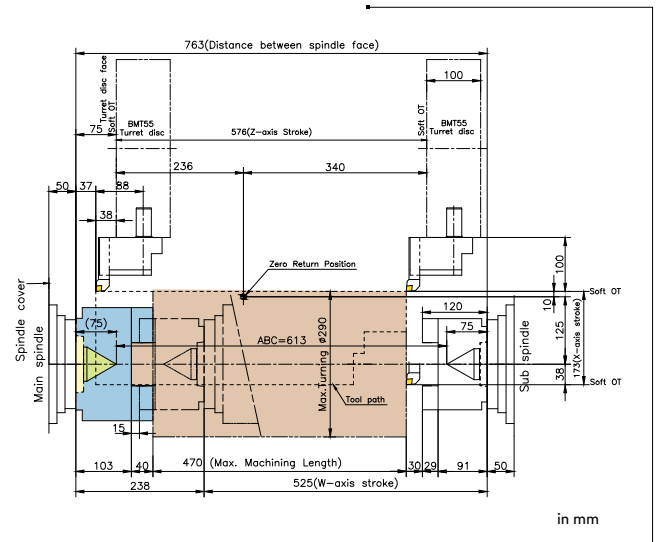

Note : 1. Refer Turret interference diagram for max. weight of tool holders on the turret disc  
 2. Mentioned indexing time in specification can be achieved based on the weight mentioned in Turret interference diagram  
 3. Turret indexing time will increase if Tool & tool holders weight are increased.  
 4. \*May vary depending upon make / model of chuck.

### TURRET INTERFERENCE

#### LL20MYS L5

12 STATION

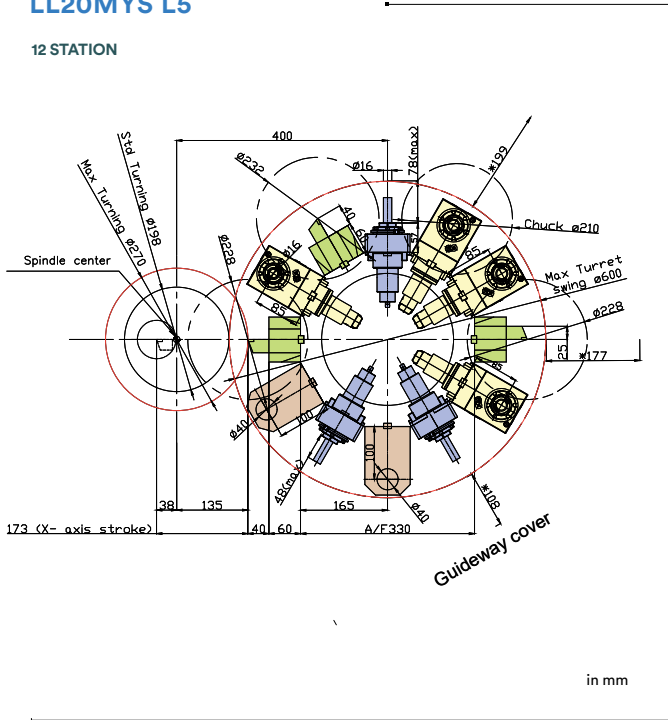

Y AXIS

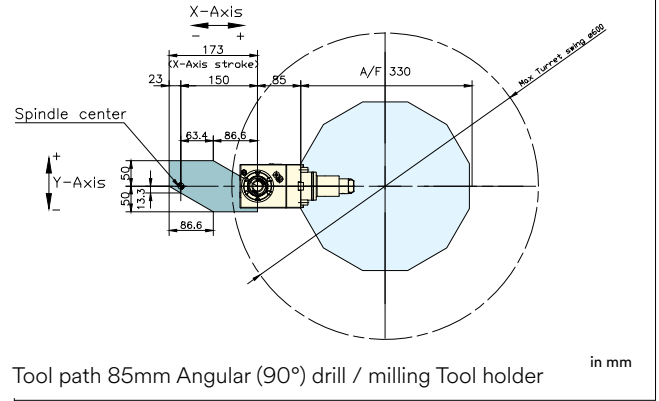

Tool path 85mm Angular (90°) drill / milling Tool holder

Note:  
Angular Tool Holder (90°) Center height CH = 85mm  
At Spindle Center + Y axis stroke = +50, - Y axis stroke = -13.3

Y AXIS

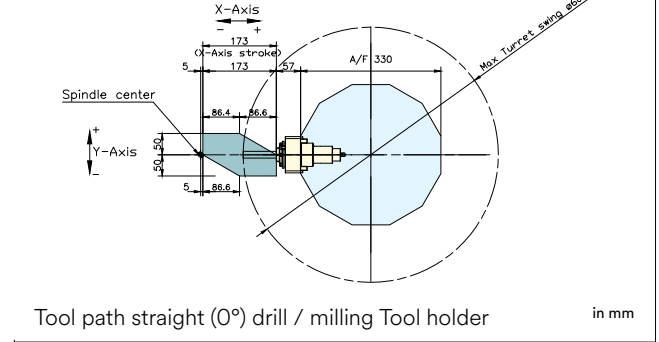

Tool path straight (0°) drill / milling Tool holder

### SPEED POWER CURVE

#### LL20MYS L5

#### MAIN SPINDLE

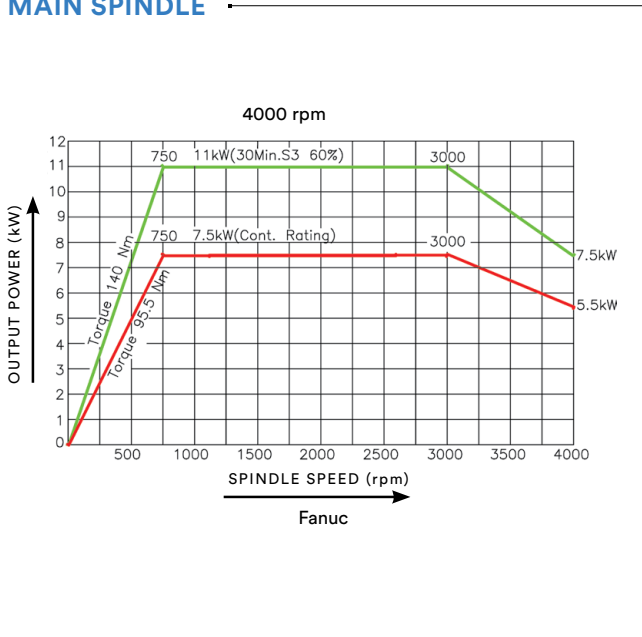

#### SUB SPINDLE

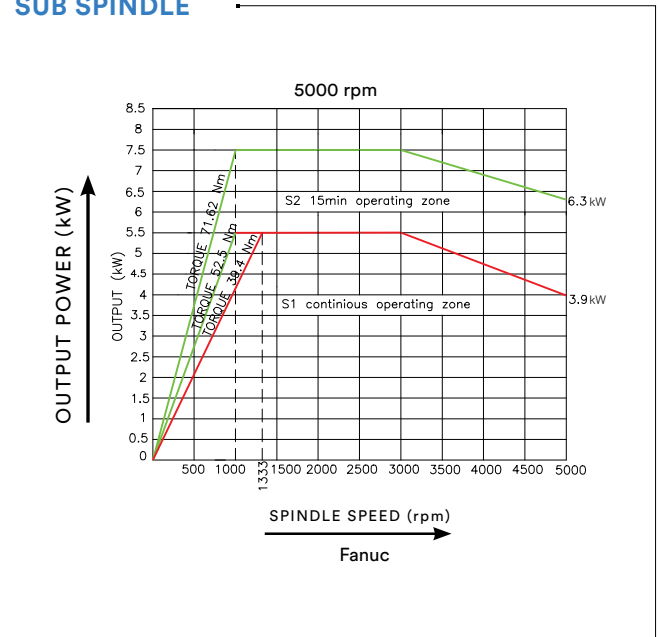

LL SERIES

BASIC INFORMATION

DIAGRAMS

SPECIFICATIONS

APPLICATIONS & SOLUTIONS

### LMW offers customized automation solutions

- To Reduce Production Cost
- To Decrease in Part Cycle Time
- To Reduce Wastage
- To Save Local Jobs
- To Stay Competitive
- For Better Floor Space Utilization

### GANTRY AUTOMATION

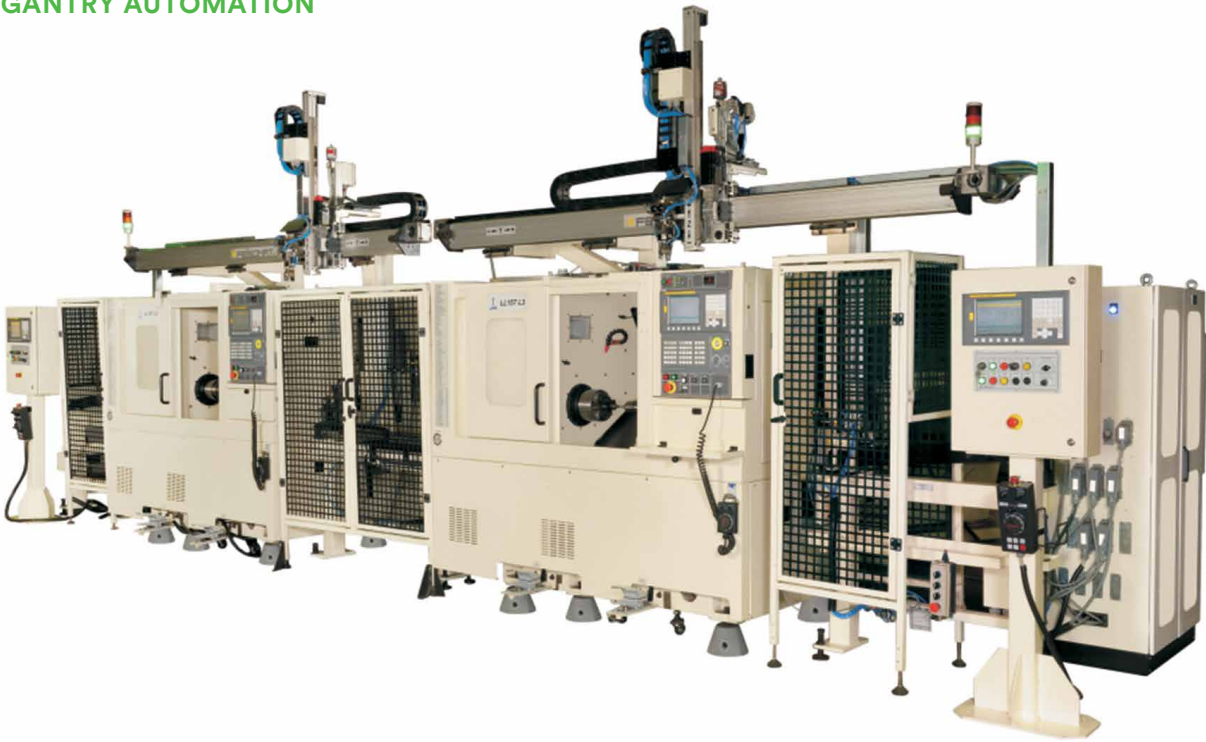

### ROBOTIC AUTOMATION

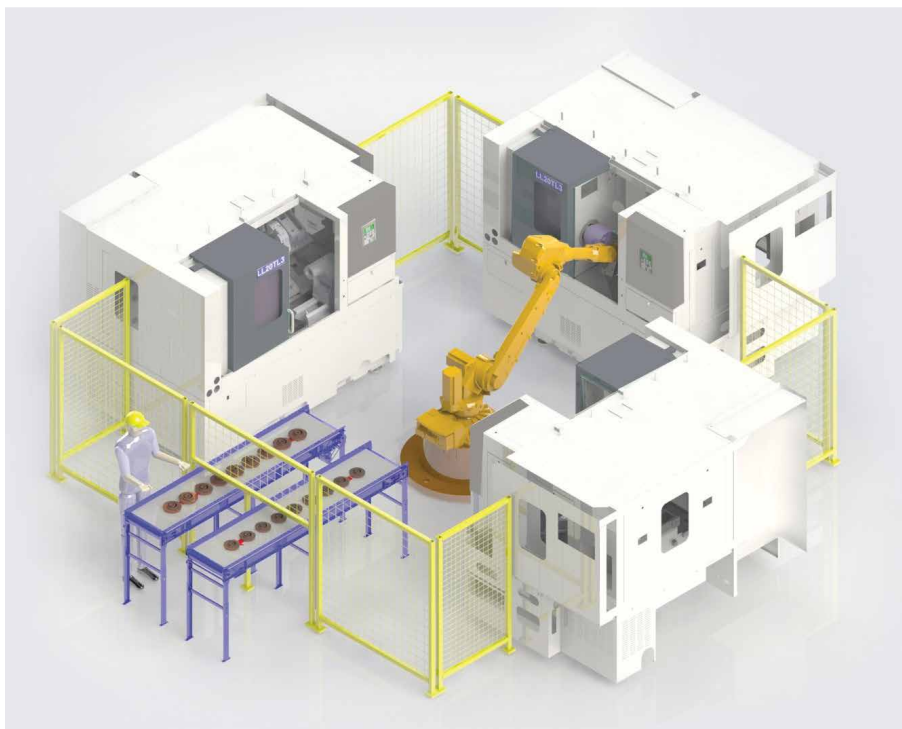

**COMPONENTS**



Gear

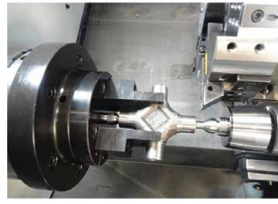

Journal Cross



Cylinder Liner



Differential Case



Spider



Connecting Rod



Universal Joint



Valve Housing



Yoke Shaft



Impeller



Bearing Collar



Pump Body



Ball Valve



Gate Valve



Pump Housing



Sprocket

**i FOCUS**  
Gateway to IOT

**INTERNET OF THINGS (IOT)**

i-Focus monitoring provides realtime dashboards that display data the way we want to see it. Customized by roll, machine type and process visibility into asset (Machines) performance and shopfloor process. Monitors data from any machine regardless of manufactures, age and CNC.

**BENEFITS**

- Increased utilization and efficiency
- Optimize down time
- Transparency and go digital

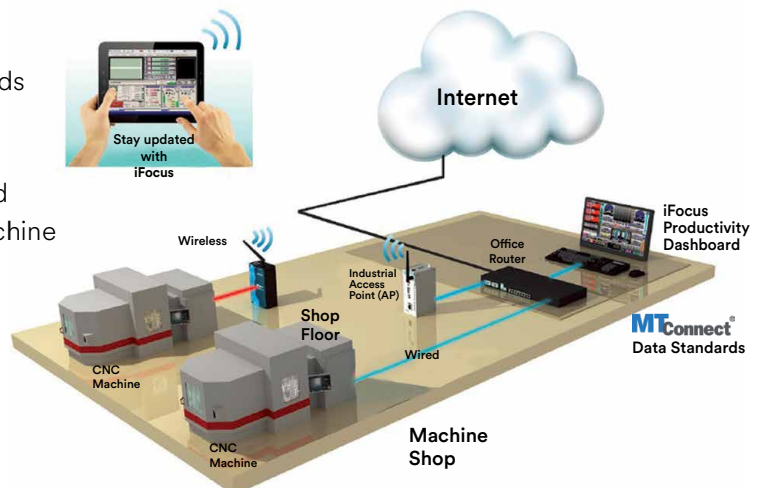

LL SERIES

BASIC INFORMATION

DIAGRAMS

SPECIFICATIONS

APPLICATIONS & SOLUTIONS

[www.lmwcnc.com](http://www.lmwcnc.com)



INDIA'S FINEST  
RANGE OF CNC MACHINES

FOLLOW US ON:



LMW CNC



INTEGRATED SOLUTIONS



**LMW LIMITED**

MACHINE TOOL DIVISION  
Arasur, COIMBATORE - 641 407, Tamil Nadu, India.  
Tel: +91 422 719 1300