



LF
SERIES

TWIN SPINDLE CHUCKER



TWIN SPINDLE TWIN TURRET CHUCKER - Front Loading

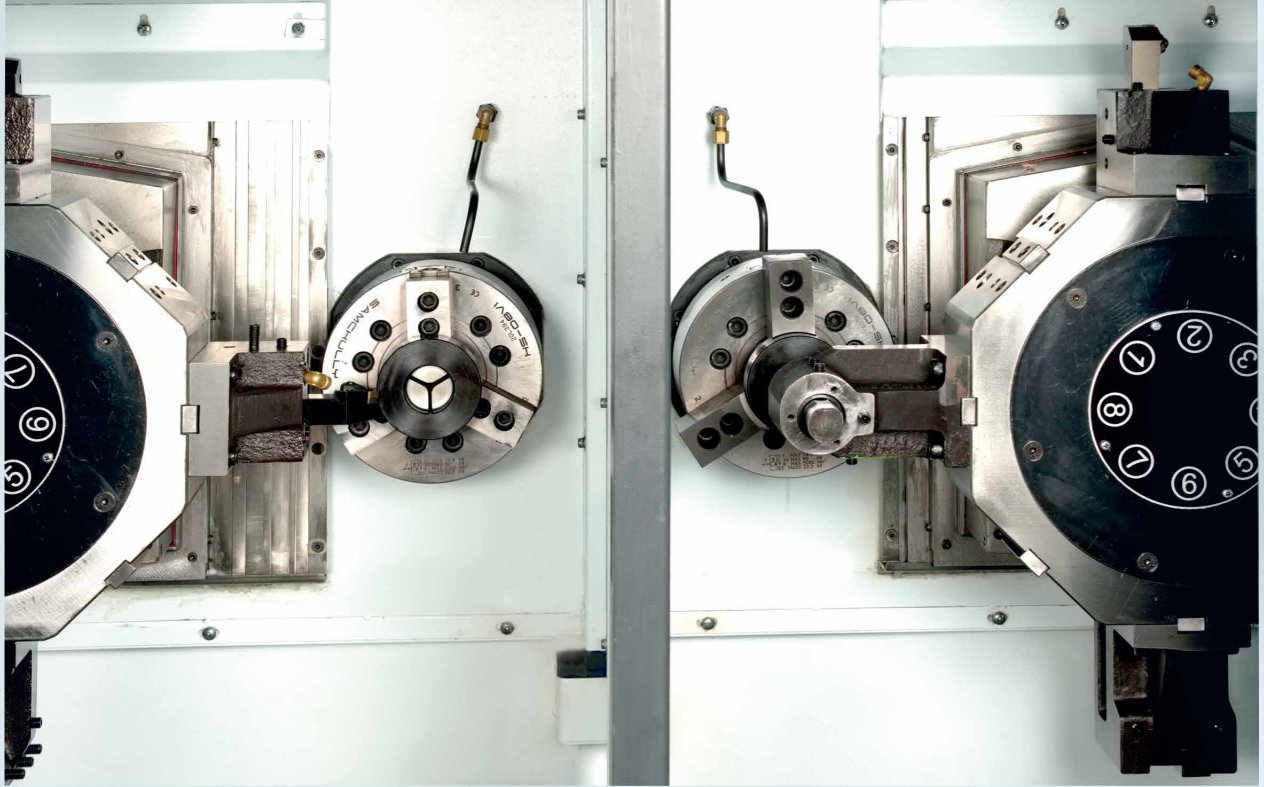

PRODUCTIVE SERIES

LF series - twin spindle and twin turret chucker with add-on gantry automation supports process integration, flexible parts manufacturing with high productivity and accuracy.

Highly suitable for variety of high volume components in Automotive, bearing, Fittings, Pump & valves etc.

FEATURES

- Simultaneous front & back machining and symmetrical machining with excellent efficiency
- Short cycle time
- Hard Part turning and high precision capability
- Ideal for high volume part production
- Easy coolant and chip management
- Gantry Loader (optional)

BASIC STRUCTURE

- Rigid machine Structure, high dampening for low vibrations and thermal stability
- Parallel spindle and turret arrangement supports heavy cuts, accurate finishing and free chip flow.
- FG 300 Cast Iron Structure for excellent process stability and tool life.

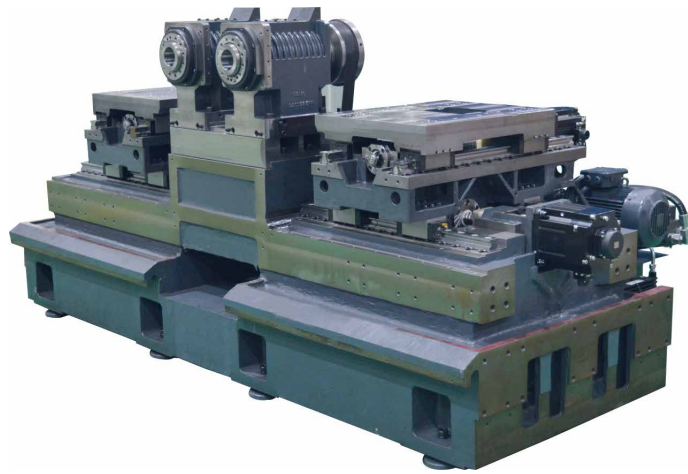

MACHINING AREA

- LF series offers machining area upto Ø240mm and 117mm max. turning diameter and max. turning length respectively.

Max. Turning diameter
Ø240 mm
Max. Turning length
117 mm

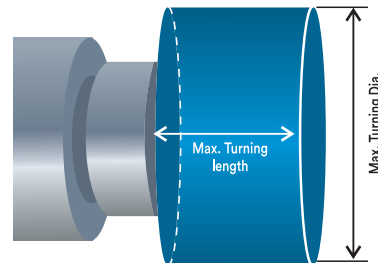

TWIN SPINDLE

- High power, high torque motors for heavy duty cutting enhancing productivity

Max. spindle speed
4000 rpm
Max. Spindle Power
11/7.5 kW
Max. Spindle Torque
140/71 Nm



TWIN TURRET

- Rigid hydraulic turret provide high clamping force, provides high accuracy and superior performance for turning, drilling, tapping and threading operations etc.

2 Axis Turret
8 + 8
Tool shank
25 x 25 mm
Max. Boring bar dia
40 mm



LF SERIES

BASIC INFORMATION

APPLICATION

SPECIFICATIONS

DIAGRAMS

HIGH SPEED GANTRY LOADER

- The 3 Axis CNC servo driven, high speed gantry loader provides minimized work loading / unloading time and maximize productivity

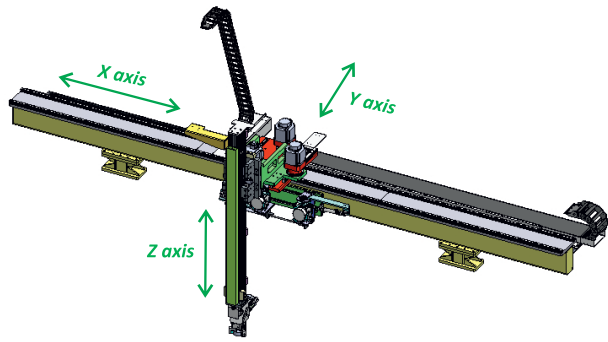

EASY OF ACCESS

- The independent front doors of the machine allows the operator convenient access to both spindles
- Ergonomical design for ease of operations

FLOOR SPACE - COMPARISON

- **50%** Space reduction
(Gantry not included)

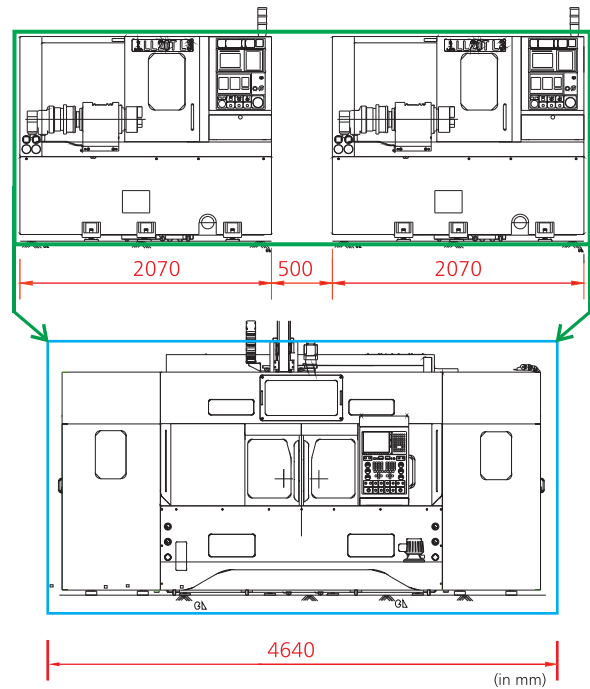
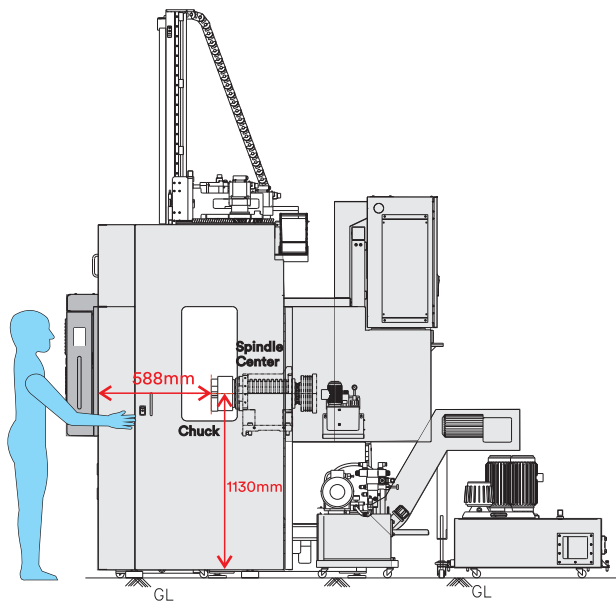

INSTALLATION DIAGRAM

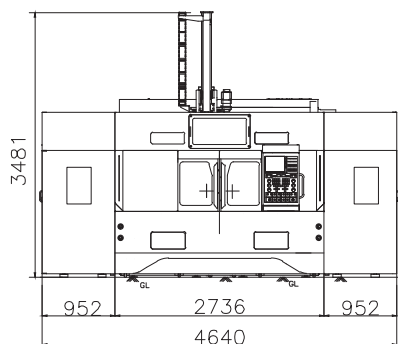

FRONT VIEW

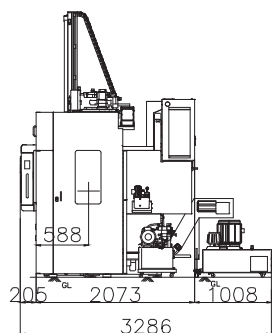

SIDE VIEW

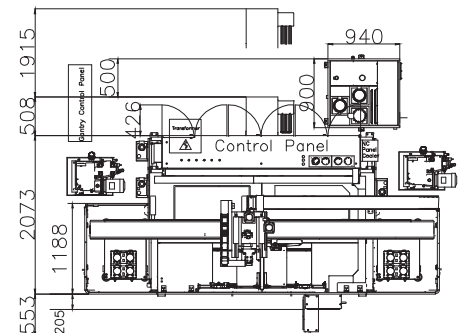

TOP VIEW

EASY OPERATING SCREEN

Maintenance navigation screen

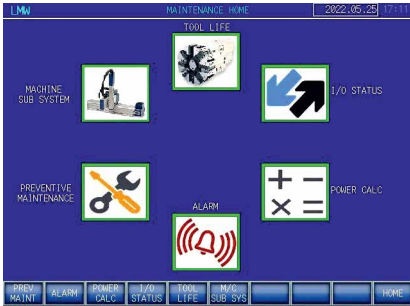

Dashboard helps to perform / reach desired screen by quick navigation

Spindle power calculator

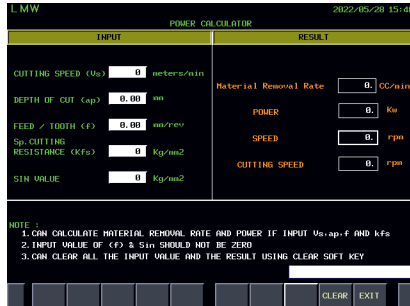

Programmer can Calculate spindle power, spindle load as exactly as on screen

Turret I/O status screen

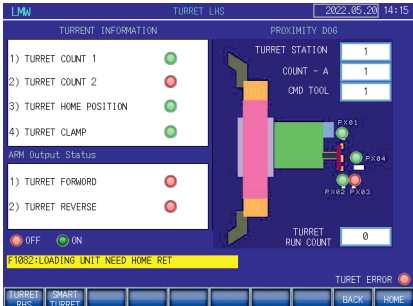

This screen helps to diagnosis of Input / Output and trouble shooting

Gantry programming screen

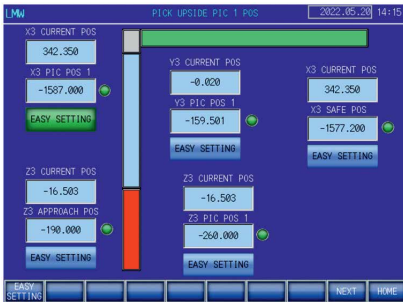

This screen for gantry program for various components

Automation system monitoring screen

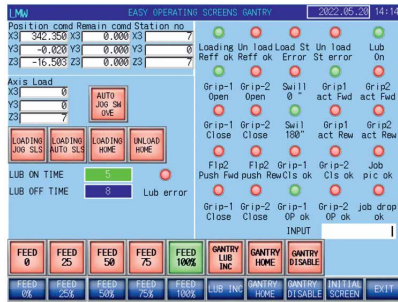

Gantry status screen

Preventive maintenance screen



Maintenance schedules as on the screen

MACHINING PERFORMANCE

Material Removal Rate (STEEL- EN9)

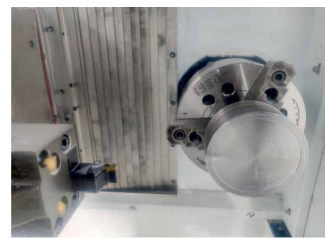
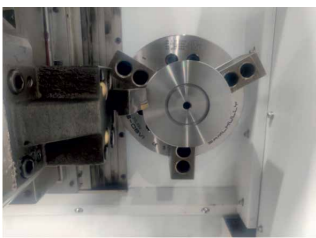

Turning Test		
Parameter	Unit	Values
Diameter	mm	105
Cutting Speed	rpm	225
Spindle Speed	rpm	762
DOC	mm	5.5
Feed	mm/rev	0.2
Capacity	cc/min	248

Drilling Test		
Parameter	Unit	Values
Diameter	mm	32x2z
Spindle Speed	rpm	1500
Feed	mm/rev	0.1
Depth	mm	32

Tapping Test		
Parameter	Unit	Values
Tap Size	mm	M16x2
Spindle Speed	rpm	300
Feed	mm/rev	2
Depth	mm	25

Threading Test		
Parameter	Unit	Values
Thread	mm	M24x3
Spindle Speed	rpm	800
Feed	mm/rev	3
Length	mm	30

Note : Values shown are in test conditions, may vary depending on tools, materials and cutting parameters / conditions

LF SERIES

BASIC INFORMATION

APPLICATION

SPECIFICATIONS

DIAGRAMS

SPECIFICATIONS

DESCRIPTION		UNIT	LF20 C Twin G
CAPACITY	Maximum swing over	mm	Ø325
	Maximum Turning diameter	mm	240
	Maximum Turning length	mm	117
SPINDLE	Spindle Nose	-	A2-6
	Hole through spindle	mm	Ø61
	Spindle speed	rpm	4000
	Spindle Motor Power (Cont. / 15 min)	Kw	7.5/11
	Max. Spindle Torque (Cont. / 15 min)	Nm	71 /140
TURRET	Number of Stations	Nos	8
	Tool Shank Size	mm	25 x 25
	Maximum boring bar diameter	mm	40
	Indexing Time (per station)	sec	1
FEED SYSTEM	Cross Travel (X - Axis)	mm	200
	Longitudinal travel (Z - Axis)	mm	160
	Rapid traverse (X , Z - Axes)	m / min	24
MACHINE SIZE	L x B x H (w/o chip conveyor)	mm	3481 x 4640 x 2073
	Weight	Kgs	8000
	Floor space required	m ²	15.2
ACCURACY	Positioning Accuracy (X , Z - Axes)	mm	0.005 / 0.010
	Repeatability (X , Z - Axes)	mm	±0.002 / ±0.003
CNC SYSTEM	Controller	Type	Mitsubishi
GANTRY LOADING / UNLOADING	Maximum work weight	Kg	3 x 2
	Max. Rapid traverse (GX / GY / GZ)	m / min	100 / 60 / 100
	Max. stroke (GX / GY / GZ)	mm	4000 / 150 / 1100

Note: May vary depending upon optional accessories etc.

LF SERIES

BASIC INFORMATION

APPLICATION

SPECIFICATIONS

DIAGRAMS

SPINDLE SPEED POWER DIAGRAM (LHS & RHS)

FOR 7.5 / 11 kW (MITSUBISHI)

4000 rpm

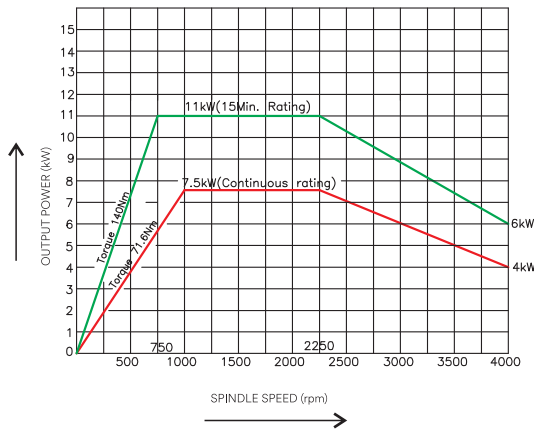

TURRET INTERFERENCE DIAGRAM

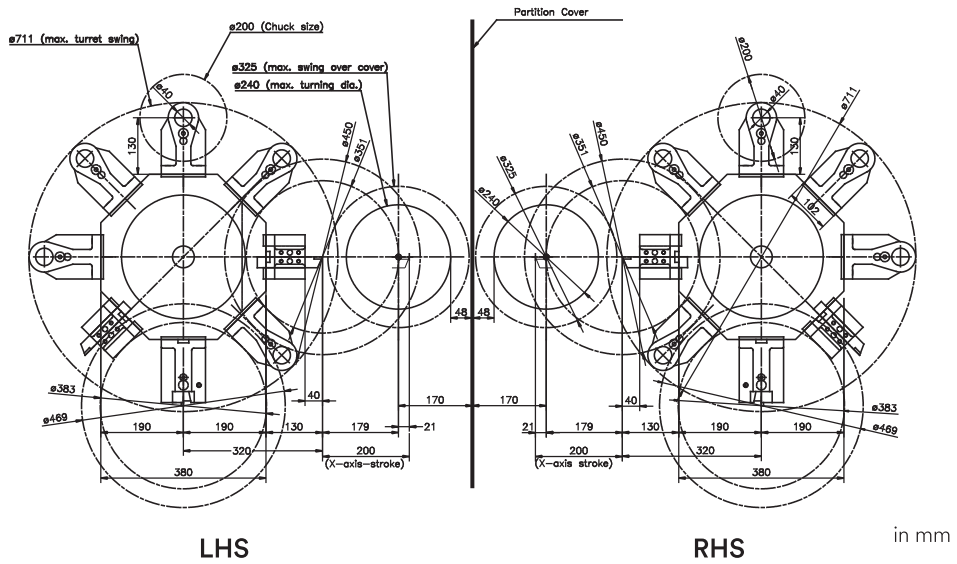

MOVING RANGE DIAGRAM

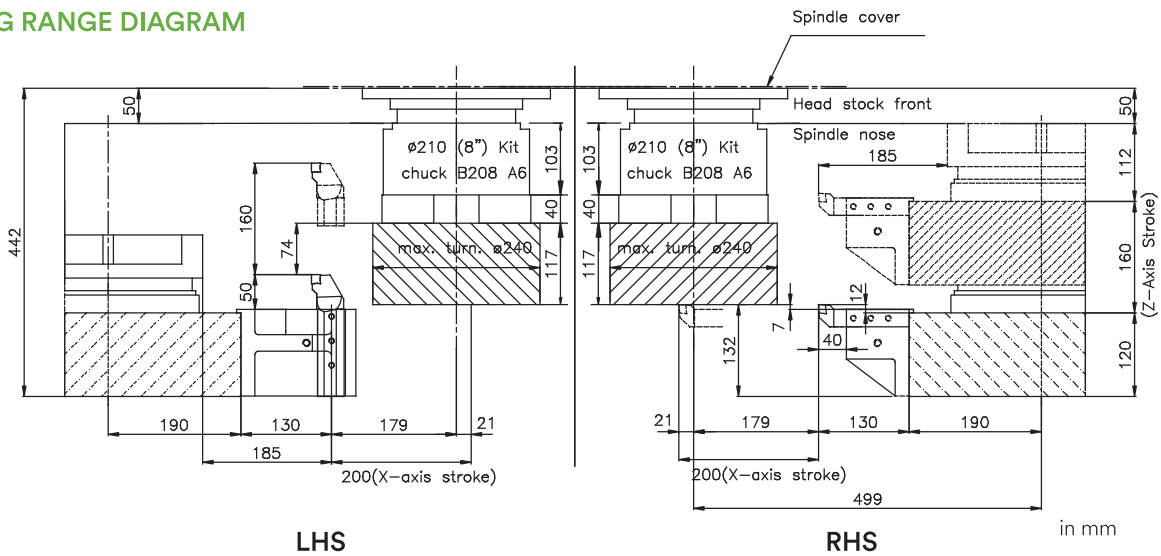

BASIC INFORMATION

APPLICATION

SPECIFICATIONS

DIAGRAMS

www.lmwcnc.com



INDIA'S FINEST
RANGE OF CNC MACHINES

FOLLOW US ON:



LMW CNC



INTEGRATED SOLUTIONS



LMW LIMITED

MACHINE TOOL DIVISION
Arasur, COIMBATORE - 641 407, Tamil Nadu, India.
Tel: +91 422 719 1300