



J SERIES

VERTICAL MACHINING CENTER



LMW
GREENAXIS
TOWARDS GREENER FUTURE



India's finest range of CNC machine manufacturer introduces new J series vertical machining centre with exceptional reliability, performance and precision. The design concept provides larger working area for ease of use with small footprint, direct coupled and belt driven spindle for precision and good surface finish, high rapid rates, high Speed/Torque characteristics and Lower chip to chip time for higher productivity. J series is versatile machine suitable for a wide variety of industrial applications such as Automobile, Die mold, Medical, Pump, Valve, Forging, Industrial machinery & General Engineering etc.

J SERIES

- ✓ Direct Coupled and Belt Driven BT40, BBT 40 & HSK A63 Spindle configurations
- ✓ Rigid structure with wider working area
- ✓ Precision Linear Motion Guideways on X Y & Z axes
- ✓ Faster tool change time
- ✓ J2, J3, J5 & J6 has Automatic Pallet Changer to achieve higher productivity and reduce non cut time
- ✓ Wider Column base ensures heavy duty machining
- ✓ Improved chip & Coolant management
- ✓ Compact foot print with larger working area

J SERIES

BASIC
INFORMATION

APPLICATIONS &
SOLUTIONS

SPECIFICATIONS

DIAGRAMS

BASIC STRUCTURE

- ✓ The core components of the machine, including the bed, column, saddle, table, and spindle head, are all made from FG 300 grade cast iron. These parts are thoroughly stress-relieved to ensure long-lasting accuracy and vibration-free machining.
- ✓ The entire machine structure undergoes Finite Element Analysis (FEA) to meticulously check its structural integrity and performance.

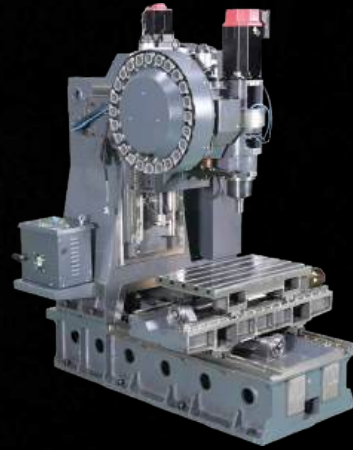

FEED MECHANISM

- ✓ J series employs high precision roller linear motion guideways & large diameter, pre-tensioned ball screws, high resolution feedback system in all axes.
- ✓ All three axes are equipped with direct drive motors and precision ball screws for optimum accuracy and rigidity.
- ✓ Laser calibration of the axis traverse ensure excellent accuracies in respective positioning as well as in interpolated cutting.
- ✓ To protect the guideways from chips and dust, they are fully enclosed by highly flexible telescopic covers.

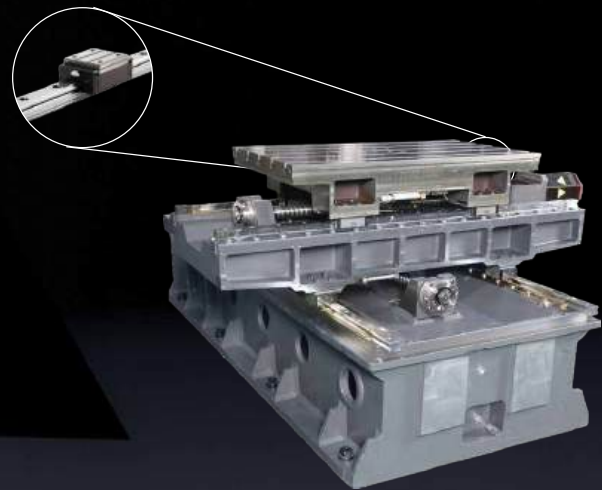

Laser calibration of all axis as per ISO 230-2 standards ensure excellent accuracies while machining close tolerance parts.

TABLE

- ✓ The series of Vertical Machining Centers (VMCs) features larger tables and increased Y-axis travel.
- ✓ J Series machines offer increased table size and higher maximum load-carrying capacity to accommodate larger and heavier workpieces.

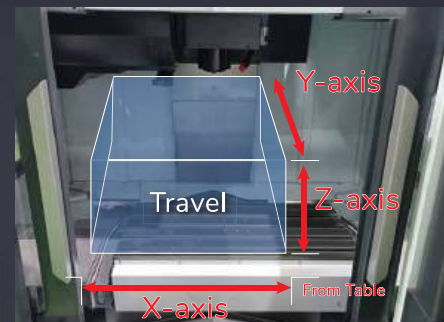

AUTOMATIC PALLET CHANGER

- ✓ Enables simultaneous machining and pallet loading/unloading, significantly reducing idle time
- ✓ J2, J3, J5 & J6 Available in both Rotary & Linear Pallet Changer

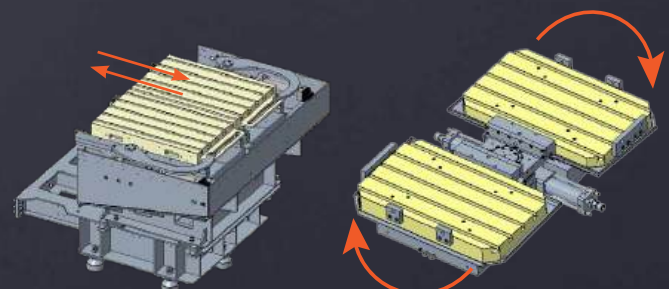

Linear Automatic Pallet Changer (LAPC)

Rotary Automatic Pallet Changer (RAPC)



SPINDLE

- ✔ Available with Direct Coupled or Belt Driven spindle configurations, enabling application-specific selection without any change in the machine structure.
- ✔ Direct Coupled spindle provides spindle speeds up to 8,000 rpm (optional 10,000 rpm) with direct power transmission, ensuring high-speed machining capability and superior surface finish.
- ✔ Belt Driven spindle is available in 5,000 rpm and 6,000 rpm variants, delivering higher torque through optimized speed ratios, making it ideal for heavy cutting applications in steel and cast iron.
- ✔ A wide power and torque range across spindle options ensures stable roughing, efficient semi-finishing, and precise finishing operations.
- ✔ An optimized constant power range supports high material removal rates at lower rpm, delivering consistent performance across varied cutting conditions.



Direct Coupled Spindle



Belt Driven Spindle

DIRECT COUPLED SPINDLE CONFIGURATION						
SPINDLE POWER (kW)			SPINDLE TORQUE (Nm)			SPINDLE SPEED (RPM)
Fanuc (Cont./ Int.)	Mitsubishi (Cont./ Int.)	Siemens (Cont./ Int.)	Fanuc (Cont./ Int.)	Mitsubishi (Cont./ Int.)	Siemens (Cont./ Int.)	Maximum (Std./Opt.)
STANDARD			STANDARD			STANDARD
11/15/18.5	11/15	11/14.3/16.5/22	52.5/70/95.5/118	52.5/71.6/95.5	70/91/105/140	8000/10000
OPTION			OPTION			OPTION
15/18.5	15/18.5	15/19.5/22.5/30	71.6/95.5/118	95.5/118	71.5/93/107.5/143	8000

BELT DRIVEN SPINDLE CONFIGURATION						
SPINDLE POWER (kW)			SPINDLE TORQUE (Nm)			SPINDLE SPEED (RPM)
Fanuc (Cont./ Int.)	Mitsubishi (Cont./ Int.)	Siemens (Cont./ Int.)	Fanuc (Cont./ Int.)	Mitsubishi (Cont./ Int.)	Siemens (Cont./ Int.)	Maximum (Std./Opt.)
STANDARD			STANDARD			STANDARD
11/15/18.5	11/15	11/14.3/16.5/22	78.8/105/143/177	78.8/107.4/143.3	105/136.5/157.5/210	5000
11/15/18.5	11/15	11/14.3/16.5/22	70/93.3/127.3/157.3	70/95.5/127.3	93.3/121.3/140/186.7	6000
OPTION			OPTION			OPTION
15/18.5/22	15/18.5	15/19.5/22.5/30	107.4/143/177	143.3/177	107/139.5/161/214.5	5000
15/18.5	15/18.5	15/19.5/22.5/30	95.5/127.3	127.3/157.3	95.3/124/143.3/190.7	6000

AUTOMATIC TOOL CHANGER

- ✔ Twin arm type with automatic tool changer.
- ✔ High speed 24 pocket tool magazine with faster tool change which reduces the non cutting time.
- ✔ Rapid tool clamp / Declamp arrangement.

24 TOOL ARM TYPE ATC

No of Tools: 24
Tool to Tool Time:



EASY ACCESSIBILITY

- ✔ With wider opening (double door) crane accessibility is quick and easy.
- ✔ Easy to load components and automation friendly.
- ✔ With excellent access to the table, spindle and operator panel helps in loading / unloading setup operations such as fixture adjustment can be done smoothly.

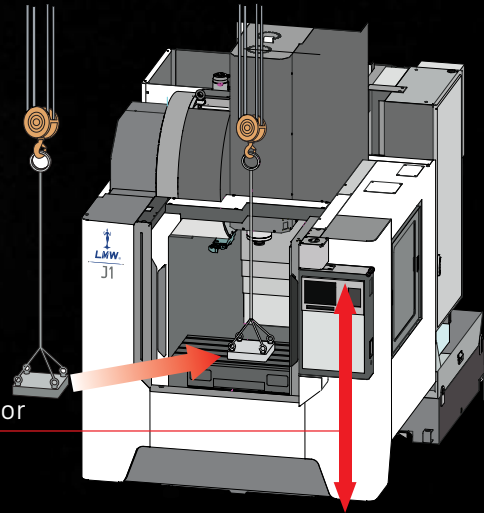

Distance from the Floor to operator Panel

1620 mm

Distance from the front of the machine to the spindle center

830 mm

Distance from floor surface to table surface

950 mm

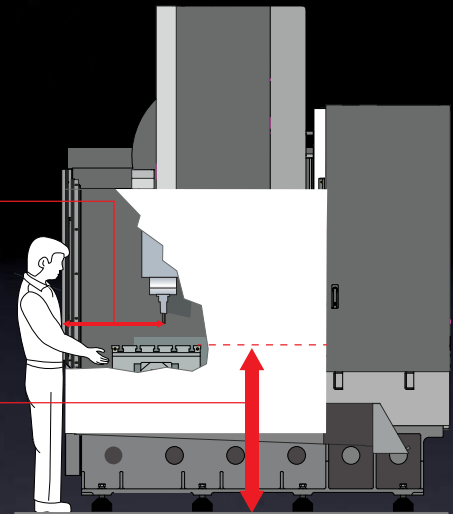

	J1	J2	J3	J5	J6
Door Opening (in mm)	790	930	1117	930	1117

WIDER DOOR OPENING

SHORTER DISTANCE FROM DOOR TO TABLE

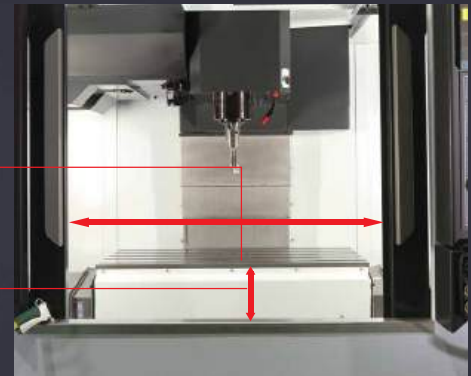

EASE OF OPERATION

- ✔ The operator panel can swivel from 0° to 90° with six intermittent stop arrangement.



SPECIFICATIONS

DESCRIPTION	UNIT	J1	J2	J3	J5	J6	J2R	J6R	J2L
TRAVEL									
X Axis	mm	600	800	1000	800	1000	800	1000	800
Y Axis	mm	500			600	600	500	600	520
Z Axis	mm	500			600	600	500	600	520
Distance between Spindle nose & Table top		150-650			150-750		150-650	145-745	150-670
TABLE									
Table Size	mm	900 X 500	1000 X 500	1200 X 500	1000 X 600	1200 X 600	-		
Table Loading Capacity	kg	500	800	800	800	800	-		
No. of T-slots	Nos.	5					-		
T-slot Size x pitch	mm	18 X 100					-		
SPINDLE									
Spindle Type	Type	Direct Coupled / Belt Driven							
Spindle Bore Taper	Type	BT 40 (BBT 40 / HSK A63)							
Front Bearing Inner Diameter	mm	Ø70							
Lubrication for Spindle	-	Grease							
Direct Coupled									
Max. Spindle Speed	Rpm	8000 (10000*)							
Spindle Motor Power (Cont. /Int.) - Fanuc	kW	11/15/18.5 (15/18.5)							
Max. Spindle Torque - Fanuc	Nm	52.5/70/95.5/118 (71.6/95.5)							
Spindle Motor Power (Cont. /Int.) - Mitsubishi	kW	11/15 (15/18.5)							
Max. Spindle Torque - Mitsubishi	Nm	52.5/71.6/95.5 (95.5/118)							
Spindle Motor Power (Cont. /Int.) - Siemens	kW	11/14.3/16.5/22 (15/19.5/22.5/30)							
Max. Spindle Torque - Siemens	Nm	70/91/105/140 (71.5/93/107.5/143)							
Belt Driven - 5000 RPM									
Spindle Motor Power (Cont. /Int.) - Fanuc	kW	11/15/18.5 (15/18.5)							
Max. Spindle Torque - Fanuc	Nm	78.8/105/143/177 (107.4/143)							
Spindle Motor Power (Cont. /Int.) - Mitsubishi	kW	11/15 (15/18.5)							
Max. Spindle Torque - Mitsubishi	Nm	78.8/107.4/143.3 (143.3/177)							
Spindle Motor Power (Cont. /Int.) - Siemens	kW	11/14.3/16.5/22 (15/19.5/22.5/30)							
Max. Spindle Torque - Siemens	Nm	105/136.5/157.5/210 (107/139.5/161/214.5)							
Belt Driven - 6000 RPM									
Spindle Motor Power (Cont. /Int.) - Fanuc	kW	11/15/18.5 (15/18.5)							
Max. Spindle Torque - Fanuc	Nm	70/93.3/127.3/157.3 (95.5/127.3)							
Spindle Motor Power (Cont. /Int.) - Mitsubishi	kW	11/15 (15/18.5)							
Max. Spindle Torque - Mitsubishi	Nm	70/95.5/127.3 (127.3/157.3)							
Spindle Motor Power (Cont. /Int.) - Siemens	kW	11/14.3/16.5/22 (15/19.5/22.5/30)							
Max. Spindle Torque - Siemens	Nm	93.3/121.3/140/186.7 (95.3/124/143.3/190.7)							

Note: *10000 rpm is not available in 15/18.5 Fanuc

J SERIES

BASIC
INFORMATION

APPLICATIONS &
SOLUTIONS

SPECIFICATIONS

DIAGRAMS

SPECIFICATIONS

DESCRIPTION	UNIT	J1	J2	J3	J5	J6	J2R	J6R	J2L	
AUTOMATIC PALLET CHANGER										
Pallet Size	mm	-					600 x 400	850 x 500	800 x 500	
Pallet Loading Capacity	kg	-					2 x 250	2 x 300	2 x 350	
Pallet Change Type	type	-					Rotary			Linear
Pallet Indexing Time	sec	-					14	18.5	18	
No. of T-Slots	nos	-					4	5		
T-Slot Size X Pitch	mm	-					14 x 100	18 x 100		
FEED SYSTEM										
Rapid Traverse rate (X/Y/Z) - Axis	m/min	40/40/40	36/36/36	40/40/40	36/36/36	40/40/40	36/36/36	30/40/40		
Feed motor power - X, Y & Z - Fanuc	kW	2.5 / 2.5 / 4.3 (2.5/2.5/4.6)								
Feed motor torque - X, Y & Z - Fanuc	Nm	12 / 12 / 22 (12/12/30)								
Feed motor power - X, Y & Z - Mitsubishi	kW	2.2 / 2.2 / 3 (2.2/2.2/4.5)								
Feed motor torque - X, Y & Z - Mitsubishi	Nm	12/12/22.5 (12/12/30)								
Feed motor power - X, Y & Z - Siemens	kW	2.85 / 2.85 / 3.55 (2.85/2.85/4)								
Feed motor torque - X, Y & Z - Siemens	Nm	12/12/22 (12/12/27)								
Cutting Feed rate	m/min	10								
Guideways on all axes	Type	Roller LM guideways								
Ballscrew Size X,Y & Z Axes (DiaXPitch)	mm	Ø40 X 16	Ø40 X 12	Ø40 X 16	Ø40 X 12	Ø40 X 16	Ø40 X 12	Ø40 X 12 / 16		
AUTOMATIC TOOL CHANGER										
No. of Tools	Nos	24 (30)								
Tool Shank Configuration	Type	BT 40								
Max. Tool dia with adjacent tool	mm	Ø 80								
Max. Tool dia without adjacent tool	mm	Ø 125								
Max. Tool length	mm	250	300							
Max. Tool weight	kg	8								
Tool change time (tool to tool)	Sec	1.9 / 2.5*								
Tool change time (chip to chip)	Sec	5.3								
GENERAL										
Length	mm	1900	2200	2535	2200	2535	2345	2345	3110	
Width x Height	mm	3110 X 2845			3110 X 2945		3690 x 2905	3950 x 3050	3120 x 2845	
Weight	kg	4500	5000	5500	5000	5500	5500	6000	6000	
Floor Space (Aprox)	m ²	5.9	6.8	7.9	6.8	7.9	7.2	9.26	9.7	
Coolant Tank Capacity	ltr	400								
ACCURACY										
Positioning Accuracy (X, Y & Z) - Axis	mm	0.010								
Repeatability	mm	±0.003								
CNC SYSTEM										
Controller	Type	Fanuc / Siemens / Mitsubishi								
POWER SUPPLY										
Power Requirement	kVA	30 (35)								

Note: *Applicable for Belt Driven Spindle

Specifications are subject to change without prior notice & may vary depending upon optional accessories



MOVING RANGE

J1

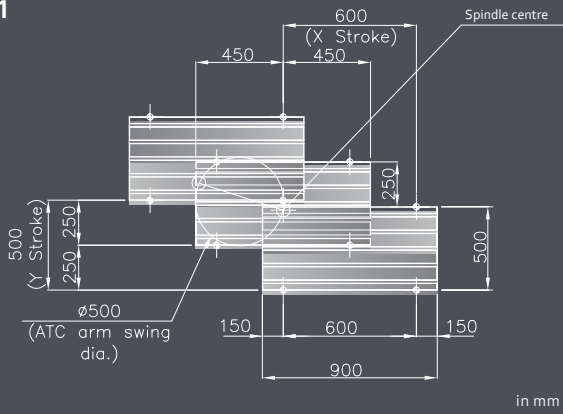

J2

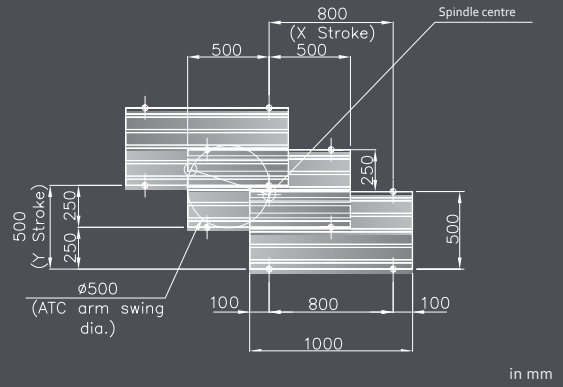

J3

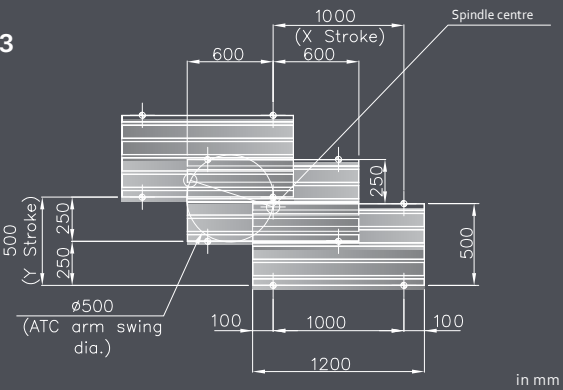

J5

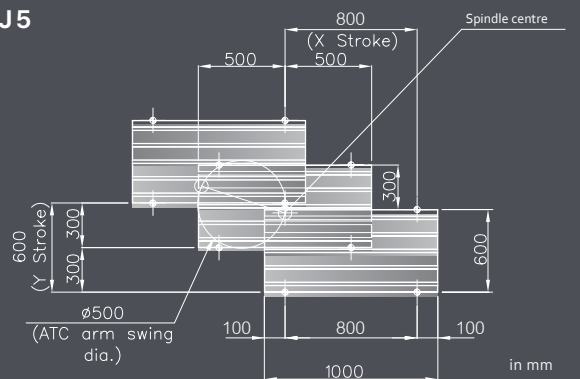

J6

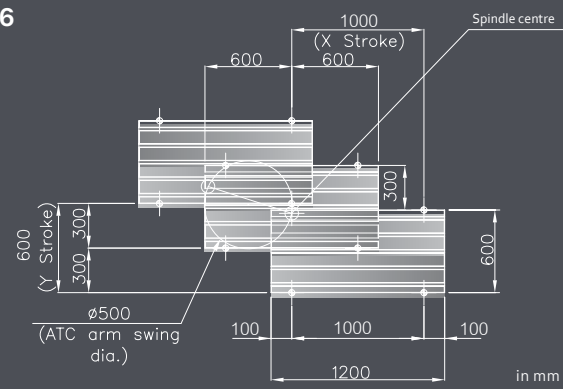

J2R

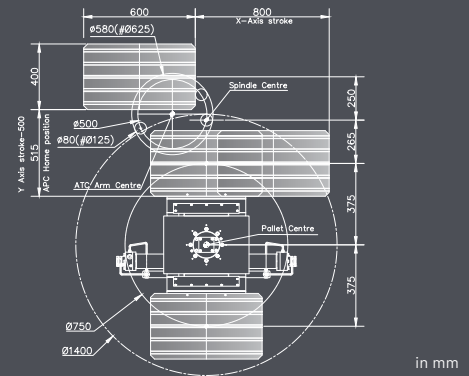

J6R

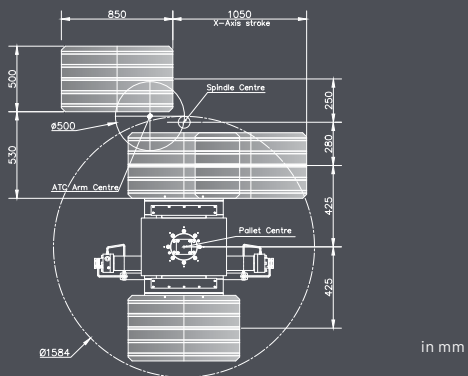

J2L

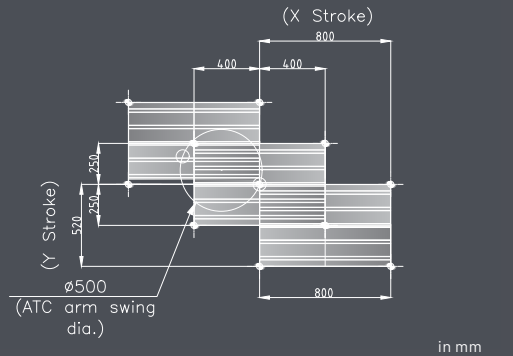

SPINDLE SPEED POWER DIAGRAM

DIRECT COUPLED - STANDARD

FANUC

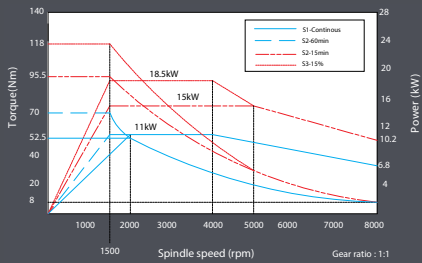

MITSUBISHI

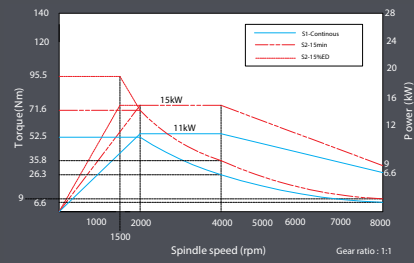

SIEMENS

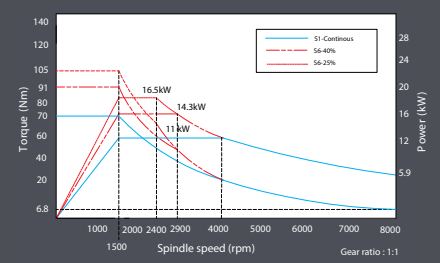

DIRECT COUPLED - OPTION

FANUC

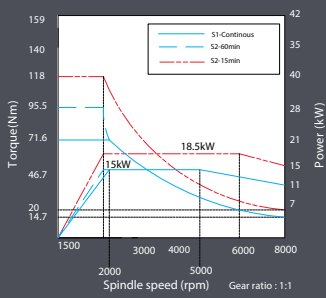

MITSUBISHI

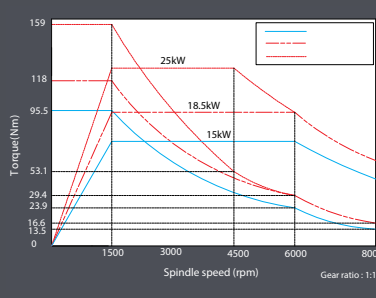

SIEMENS

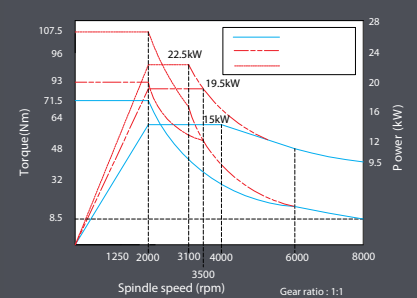

BELT DRIVEN - STANDARD

5000 RPM

FANUC

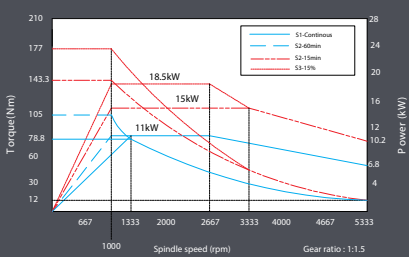

MITSUBISHI

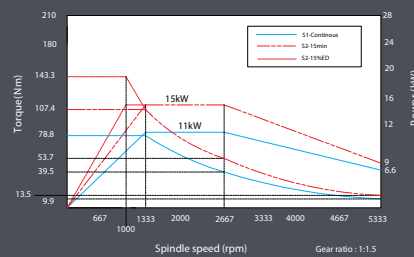

SIEMENS

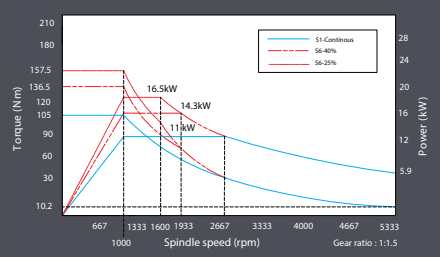

BELT DRIVEN - STANDARD

6000 RPM

FANUC

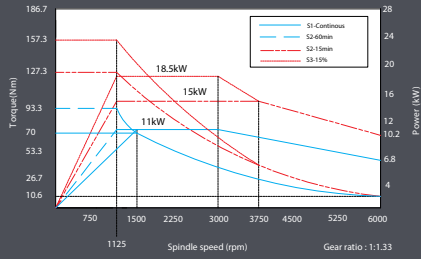

MITSUBISHI

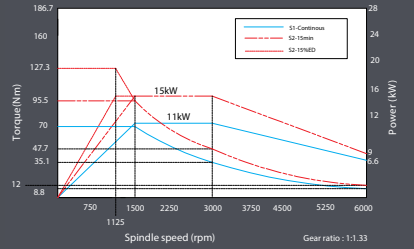

SIEMENS

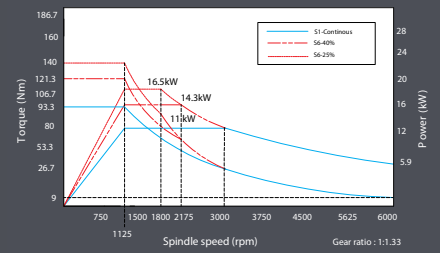

BELT DRIVEN - OPTION

5000 RPM

FANUC

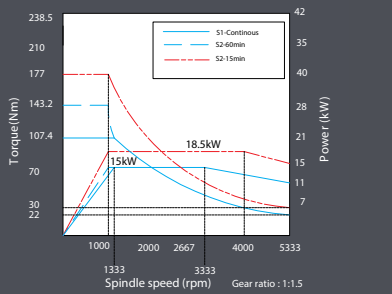

MITSUBISHI

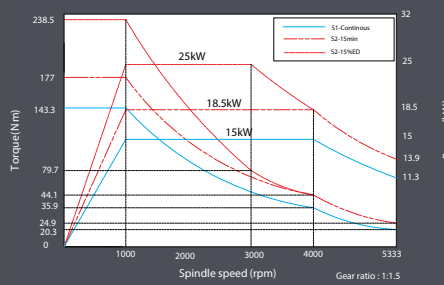

SIEMENS

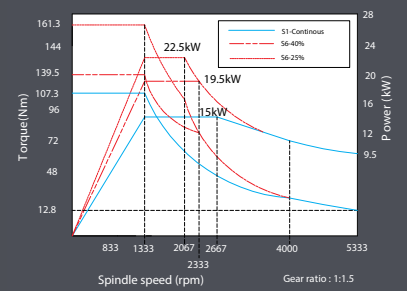

BELT DRIVEN - OPTION

6000 RPM

FANUC

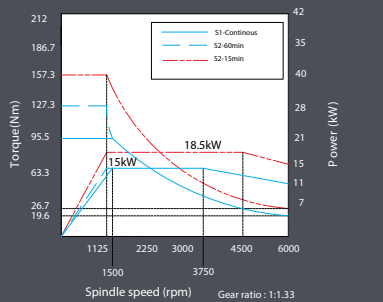

MITSUBISHI

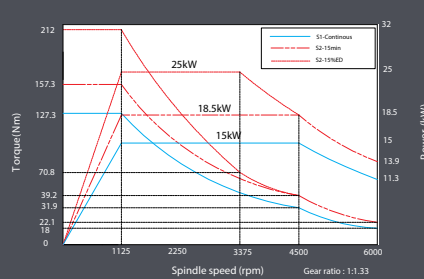

SIEMENS

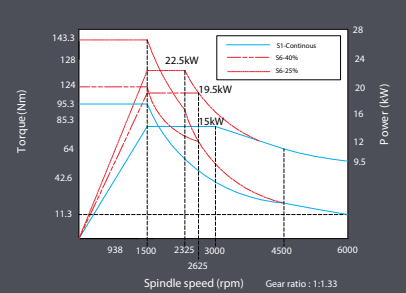

STANDARD / OPTIONAL ACCESSORIES

• Standard o Optional X Not applicable

S.NO	FEATURES	J1	J2 / J2R / J2L	J3	J5	J6 / J6R
1.	Direct coupled spindle - 8000 rpm	•	•	•	•	•
2.	24 tools ATC, BT40	•	•	•	•	•
3.	45° pull stud - 24 Nos	•	•	•	•	•
4.	Fully enclosed cover	•	•	•	•	•
5.	Telescopic covers	•	•	•	•	•
6.	Swivel type operator panel	•	•	•	•	•
7.	Linear motion guideways X,Y & Z axes	•	•	•	•	•
8.	Coolant tank - 400 litres	•	•	•	•	•
9.	Chip tray on machine rear - 2 Nos	•	•	•	•	•
10.	Coolant flush system - 250 lpm,1.5 bar	•	•	•	•	•
11.	Ring around spindle coolant - 60 lpm,4 bar	•	•	•	•	•
12.	Hand held coolant gun	•	•	•	•	•
13.	Coolant level indicator with feedback	•	•	•	•	•
14.	Automatic centralised oil lubrication with fault detection	•	•	•	•	•
15.	"T" nuts for table - 4 Nos	•	•	•	•	•
16.	Spindle air blow	•	•	•	•	•
17.	Spindle air curtain	•	•	•	•	•
18.	Levelling block - 8 Nos	•	•	•	•	•
19.	Safety precaution stickers	•	•	•	•	•
20.	Colour - Pantone cool grey, Titanium grey	•	•	•	•	•
21.	NC panel cooler	•	•	•	•	•
22.	Door interlock	•	•	•	•	•
23.	100 mm High column	o	o	o	o	o
24.	200 mm High column	o	o	o	o	o
25.	Coolant thru spindle 12 bar with filtration	o	o	o	o	o
26.	Coolant thru spindle 20 bar with filtration	o	o	o	o	o
27.	Coolant thru spindle 30 bar with filtration	o	o	o	o	o
28.	Coolant thru spindle 50 bar with filtration	o	o	o	o	o

STANDARD / OPTIONAL ACCESSORIES

• Standard o Optional X Not applicable

S.NO	FEATURES	J1	J2 / J2R / J2L	J3	J5	J6 / J6R
29.	Coolant filtration-bag filter (20 microns)	o	o	o	o	o
30.	Coolant filtration-inline filter (40 microns)	o	o	o	o	o
31.	Chip conveyor - scrapper with drum filter	o	o	o	o	o
32.	Chip conveyor - chain with drum filter	o	o	o	o	o
33.	Chip Auger	o	o	o	o	o
34.	Air drier unit - 25 cfm	•	•	•	•	•
35.	Chip trolley for chip conveyor	o	o	o	o	o
36.	Right angle head mounting provision	o	o	o	o	o
37.	Automatic centralised grease lubrication with fault detection	o	o	o	o	o
38.	Auto door	o	o	o	o	o
39.	Air compressor	o	o	o	o	o
40.	Cold air gun for dry cut	o	o	o	o	o
41.	Air catch sensor	o	o	o	o	o
42.	Mist collector	o	o	o	o	o
43.	Sub table	o	o	o	o	o
44.	Normal running spares	o	o	o	o	o
45.	Linear scale for X, Y & Z axes	o	o	o	o	o
46.	Roller LM guide	•	•	•	•	•
47.	Safety light curtain	o	o	o	o	o
48.	Additional pull stud (45°)	o	o	o	o	o
49.	Rotary table Ø200	o	o	o	o	o
50.	Rotary table Ø250	o	o	o	o	o
51.	Rotary table Ø320	o	o	o	o	o
52.	Rotary production system Ø200	o	o	o	o	o
53.	Rotary production system Ø250	o	o	o	o	o
54.	Rotary tilting table Ø200	o	o	o	o	o
55.	Rotary tilting table Ø250	o	o	o	o	o
56.	Oil skimmer	o	o	o	o	o



EASY OPERATING SCREEN (LMW-EOS)

QUICK MAGAZINE VIEW



Quick magazine view displays magazine overview like pot location, current spindle tool and waiting tool status also helps for trouble shooting.

TOOL DATA MANAGEMENT



Tool data management displays tool data overview like Tool name & number / Pot number, Tool type (Big tool / Fixed tool), Spindle tool status, Load setting for each tool.

SPINDLE LOAD MONITORING



Spindle load monitoring use to monitor the spindle load current for each tool. If the spindle current exceeds a preset load value, it raises an alarm to shut down the machine.

HARD PROBING



Hard probing is a process which is used to measure the centre of inner and outer wall of circle and rectangle by using rigid tool without probe.

CUTTING CALCULATOR



This screen helps operator to identify the Material removal rate and power consumption details by providing cutting speed, Depth of cut, Deed/ Tooth and Spindle cutting resistance details.

MAINTENANCE DISPLAY



Maintenance display shows the maintenance schedules of the machine.

MACHINING PERFORMANCE:

SPINDLE - DIRECT COUPLED - 11 / 15 kW

FACE MILLING		
Parameter	Unit	C45 - Steel
Cutter Size	mm	Ø80x6z
Spindle speed	rpm	1000
Feed	mm/mm	1500
Width of Cut	mm	60
Depth of Cut	mm	3
Capacity	cc/min	270

TAPPING			
Parameter	Unit	C45 - Steel	
		Max	Min
Tap Size	mm	M27x3	M2x0.4
Spindle speed	rpm	235	1600
Feed	mm/mm	705	640
Depth of Cut	mm	30	6
Spindle Load	%	105	-

DRILLING		
Parameter	Unit	C45 - Steel
Cutter Size	mm	Ø50 x 2Z
Spindle speed	rpm	1270
Feed	mm/mm	190
Depth of Cut	mm	50
Spindle Load	%	224

SPINDLE - BELT DRIVEN - 11 / 15 kW

FACE MILLING		
Parameter	Unit	C45
Cutter Size	mm	Ø80 x 6Z
Spindle speed	rpm	1000
Feed	mm/mm	1500
Width of Cut	mm	60
Depth of Cut	mm	4
Capacity	cc/min	360

TAPPING			
Parameter	Unit	C45 - Steel	
		Max	Min
Tap Size	mm	M27x3	M3x0.5
Spindle speed	rpm	235	1060
Feed	mm/mm	705	530
Depth of Cut	mm	30	10
Spindle Load	%	68	-

END MILLING		
Parameter	Unit	C45
Cutter Size	mm	Ø50 x 2Z
Spindle speed	rpm	1270
Feed	mm/mm	190
Width of Cut	mm	50
Depth of Cut	mm	122

Note : Values shown are in test conditions, may vary depending on tools, materials and cutting parameters / conditions.

J SERIES

BASIC INFORMATION

APPLICATIONS & SOLUTIONS

SPECIFICATIONS

DIAGRAMS

INSTALLATION DIAGRAM

FRONT VIEW

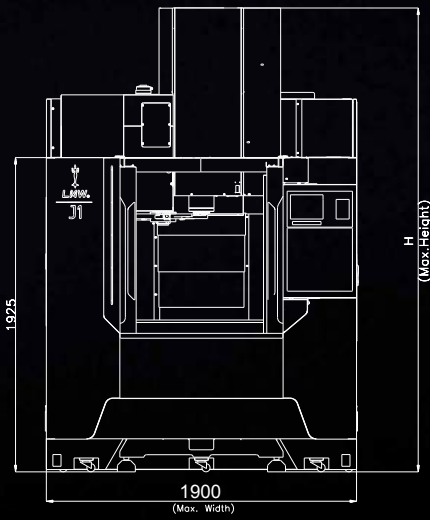

SIDE VIEW

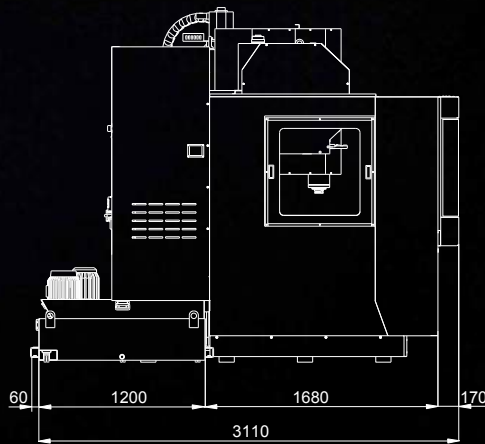

TOP VIEW

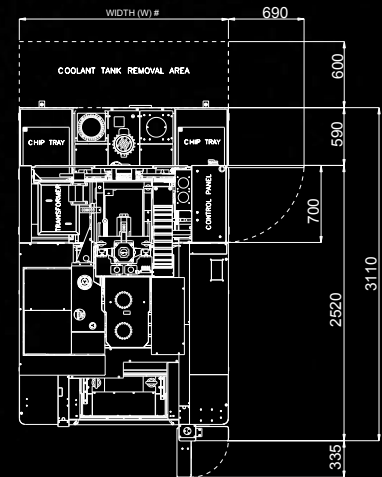

J Series		J1	J2	J3	J5	J6
Width (W)		1900	2200	2535	2200	2535
Height (H)	Std		2845		2945	
	100mm HC		2945		3045	
	200mm HC		3045		3145	

Note: HC = Height Column

MACHINING SOLUTIONS

AUTOMOBILE 2 WHEELER



4 WHEELER



DIE MOLD



PUMP & VALVE





LMW LIMITED

MACHINE TOOL DIVISION

Arasur, COIMBATORE - 641 407, Tamil Nadu, India.

Tel: +91 422 719 1300 | Email: mtdmarketing@lmw.co.in

lmwcnc.com



LMW CNC



INDIA'S FINEST
RANGE OF CNC MACHINES

Note : Specifications and colours are subject to change without prior notice. Accessories shown may not be part of standard equipment.
Values shown are in test conditions, may vary depending on tools, materials and cutting parameters / conditions.