



# JV SERIES



**JV 55**



**JV KRAFT**



**JV 80**



**JV 100**



JV SERIES

BASIC INFORMATION

SPECIFICATIONS

DIAGRAMS

APPLICATIONS & SOLUTIONS

ACCESSORIES

## JV 130

## JV 150



## JV 200



JV SERIES

BASIC INFORMATION

SPECIFICATIONS

DIAGRAMS

APPLICATIONS & SOLUTIONS

ACCESSORIES

## JV 55 TWIN

JV SERIES

BASIC INFORMATION

SPECIFICATIONS

DIAGRAMS

APPLICATIONS & SOLUTIONS

ACCESSORIES

Twin Spindle



## JVM 60

Moving Column with Rotary Pallet Changer



## MACHINE STRUCTURE

- Higher cutting capabilities with large diameter spindle bearing.
- Shorter tool length with projected spindle for better component approach and accuracy.
- Effective Power Transmission, to improve depth of cut & higher threading size.
- The stiffness built in the feed mechanism supplements the structural rigidity for higher precision machining.
- Enhanced rapid traverse rate reduces the non cut time.
- Available with swift automatic tool changer.
- Front double door design for operator friendliness and improved aesthetics.
- Through the Finite Elements Analysis (FEA), optimized FG 300 cast iron structure stable material removal and vibration free machining is possible.
- Simple to use, easy to maintain - the JV Series will truly add value to the overall manufacturing efficiency.

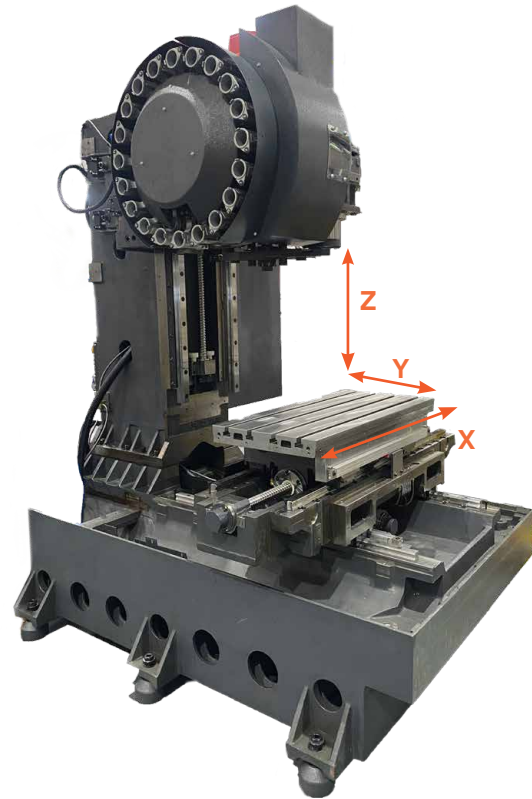

## SPINDLE HEAD

- Every Spindle Cartridge is assembled in a temperature controlled environment.
- The bearings are pre-loaded to the optimum level, so the built-in accuracies are retained over a longer period of use.



## COOLANT THROUGH SPINDLE

Provides supply of coolant through tool right upto the cutting edge to achieve excellent surface finish. A coolant filtration system is also recommended to avoid chip & dirt getting into the coolant passage of the spindle, for better finish, tool life and chip management. It comes with the choice of duplex bag hydrocyclone filtration system & compact inline filtration system for both ferrous and non-ferrous materials.



JV SERIES

BASIC INFORMATION

SPECIFICATIONS

DIAGRAMS

APPLICATIONS & SOLUTIONS

ACCESSORIES

### HIGH PRECISION FEED MECHANISM

The new JV series employs high precision linear motion guideways & large diameter, pre-tensioned ball screw for axis traverse. The locating & fixing surface for the linear motion guideways are precision machined to close tolerance in all axes for perfect seating.

### BOX GUIDEWAYS

JV 200 are provided with hardened and ground Box Guideways in the Z-Axis with sufficient wide torsion-free box type construction for better cutting performance.

### SUPERIOR LOAD CAPACITY

JV 130 & 150 is provided with 3 rows and JV 200 with 4 rows of Roller LM arranged at a contact angle of 45°, has equal load carrying rating.

### TOTALLY PROTECTED SLIDE WAYS

- The slide ways and ball screw remain completely protected, preventing entry of chips & coolant.
- This adds to ease of maintenance & retention of the built in accuracies over a long period of continuous use.

### ROTARY APC

The Automatic Pallet Changer reduces loading/unloading time and allow continuous running of the machine without stopping for component loading/unloading.

The pallet changer is compatible for 4th axis interface, hydraulic ports and supports hydraulic fixturing. The hydraulic system, provided for functioning of APC is designed to be compatible with most of the hydraulic fixtures at the user end. The APC system has minimum number of mechanical parts which allows ease of maintenance.

### ROLLER GUIDEWAYS

Rigidity : Overall rigidity of a roller-type guideways is greater because of higher rigidity of Rolling elements.

Vibration Damping is better because of roller-type guideways. Less vibration improves cutting capacity and part surface finish, and results in longer tool life.

Low rolling friction : Low friction roller guideways stabilize dimensional accuracy in surface grinding; improve the taper accuracy in internal grinding; Increase contouring accuracy in the circular milling operations of machining centers.



### EASE OF CHIP & COOLANT MANAGEMENT

- The JV series comes with a high pressure coolant pump.
- Coolant flow through nozzles at different locations carry the chips away.
- All chips are carried to rear of the machine and into the free standing chip box.
- The system allows easy clearing & maintenance.
- Direct integration with central chip management system of machining line is also possible.



### EASY OPERATING SCREEN

(LMW-EOS)

#### MAIN SCREEN

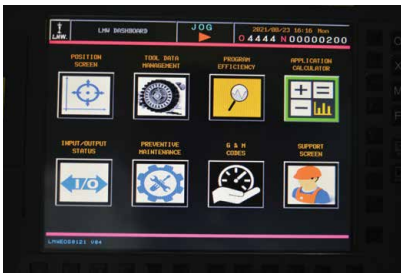

The dashboard helps to perform / reach desired screens by quick navigation.

#### QUICK MAGAZINE VIEW



Quick magazine view displays magazine overview like pot location, current spindle tool and waiting tool status also helps for trouble shooting.

#### TOOL DATA MANAGEMENT



Tool data management displays tool data overview like Tool name & number / Pot number, Tool type (Big tool / Fixed tool), Spindle tool status, Load setting for each tool.

#### SPINDLE LOAD MONITORING

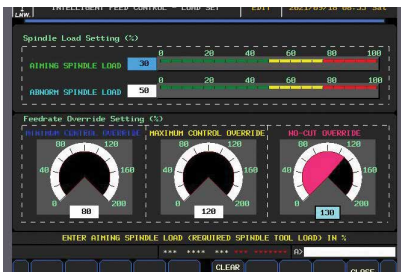

Spindle load monitoring use to monitor the spindle load current for each tool. If the spindle current exceeds a preset load value, it raises an alarm to shut down the machine.

#### SPINDLE POWER CALCULATOR

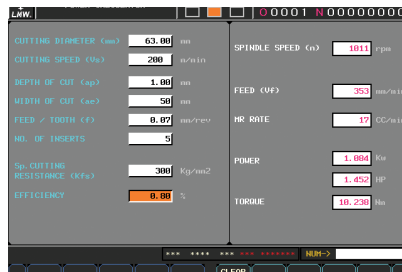

Spindle power calculator helps the programmer to calculate spindle power, spindle load as exactly as on screen.

#### MAINTENANCE DISPLAY



Maintenance display shows the maintenance schedules of the machine.



## SPECIFICATIONS

Title	Description	Unit	JV 55	JV Kraft	JV 80	JV 100
Travel / Stroke	X Axis	mm	575	800	820	1050
	Y Axis	mm	410	440	540	540
	Z Axis	mm	460	490	600	600
	Distance from spindle nose to table top	mm	140 - 600	134 - 624	125 - 725	125 - 725
Table	Table Size	mm	900 X430	1050 X 450	1000 X 560	1200 X 560
	Table Loading Capacity	kg	400	500	800	800
	T Slot Size X Pitch	nosx mmxmm	4 x 18 x 100	4 x 18 x 100	5 x 18 x100	5 x 18 x100
Spindle	Max. Spindle Speed	rpm	6000	6000	5000	5000
	Spindle Bore Taper	Type	BT 40	BT 40	BT 40	BT 40
	Motor Power ( cont / intermittent)	kW	7.5 /11	7.5 /11	11/15	11/15
	Max Spindle torque (cont / intermittent)	Nm	48/93	48 /93	78 /143	78 /143
Automatic Tool Changer	No .of tools/ Tool Selection	nos	20	20	20	20
	Tool Shank	mm	BT 40	BT 40	BT 40	BT 40
	Max tool dia with adjacent tools	mm	80	80	80	80
	Max tool dia without adjacent tools	mm	125	125	150	125
	Max. tool length	mm	250	250	350	250
	Max. tool weight on each pot	kg	7	7	7	8
	Tool change time (tool to tool)	sec	2.5	2.5	3.5	3.5
Feed System	Rapid Traverse rate (X/Y/Z)	m/min	36 / 36/ 24	36 / 36/ 24	36 / 36/ 24	36 / 36/ 24
	Cutting feed rate / Jog feed rate	m/min	10	10	20	20
Machine Size	Machine Size (LxBxH)	mm	2300 x 2680 x 2800	2300 x 2715 x 2830	2620x2860x 3165	3100x2820x 3165
	Machine weight	kg	4300	4500	5000	5500
Accuracy	Positioning Accuracy (X/Y/Z Axes)	mm	0.010	0.010	0.010	0.010
	Repeatability	mm	±0.003	±0.003	±0.003	±0.003
CNC System	Controller	type	Fanuc / Siemens / Mitsubishi			
Power Supply	Power Consumption	kVA	25	25	33	33

JV SERIES

BASIC INFORMATION

SPECIFICATIONS

DIAGRAMS

APPLICATIONS & SOLUTIONS

ACCESSORIES

Title	Description	Unit	JV 130	JV 150	JV 200	JV 55 Twin	JVM 60
Travel / Stroke	X Axis	mm	1300	1500	2000	800	640
	Y Axis	mm	700	760	900	450	460
	Z Axis	mm	650	760	800	600	600
	Distance from spindle nose to table top	mm	100 - 750	150-190	150 - 950	150 - 750	200 - 800
Table / Rotary Pallet	Table Size	mm	1350 X 660	1700 x 700	2100 X 800	1050 X 450	700 X 500
	Table Loading Capacity	kg	950	1300	2500	500	350 pallet
	T Slot Size X Pitch	nosx mmxmm	5 x 18 x 100	5 x 18 x 125	7 X 18 X 115	4 x 18 x 100	2 x18 x 100
	Pallet Indexing time	sec	-	-	-	-	8
Spindle	Max. Spindle Speed	rpm	6000	12000	4000	10000	6500
	Spindle Bore Taper	Type	BT 40	BT 40	BT 50	BBT 40	BT 40
	Motor Power ( cont / intermittent)	kW	11/15	11 / 18.5	15 / 18.5	5.5 / 7.5	7.5 /11
	Max Spindle torque (cont / intermittent)	Nm	78/143	52.5 / 118	107.4 / 177	26.3 / 47	54/105
Automatic Tool Changer	No. of tools/ Tool Selection	nos	20	24	20	20	20
	Tool Shank	mm	BT 40	BT 40	BT 50	BT 40	BT 40
	Max tool dia with adjacent tools	mm	80	80	130	80	80
	Max tool dia without adjacent tools	mm	125	125	200	125	150
	Max. tool length	mm	250	300	400	350	300
	Max. tool weight on each pot	kg	8	8	20	8	7
	Tool change time (tool to tool)	sec	3.5	2.2	4	4.5	3
Feed System	Rapid Traverse rate (X/Y/Z)	M/min	36 / 36/ 24	24/ 30 /24	20 /20/15	36/36/24	30/30/30
	Cutting feed rate / Jog feed rate	M/min	10	10	10	10	10
Machine Size	Machine Size (LxBxH)	mm	3400x4060 x2800	3620x3530 x3125	5420x4700 x3500	2550x3030x 2795	3320x2380x 3050
	Machine weight	kg	10000	10000	17000	5500	6500
Accuracy	Positioning Accuracy (X/Y/Z Axes)	mm	0.010	0.010	0.010	0.010	0.010
	Repeatability	mm	±0.003	±0.005	±0.005	±0.003	±0.003
CNC System	Controller	type	Fanuc / Siemens / Mitsubishi	Fanuc	Fanuc / Siemens / Mitsubishi	Fanuc	
Power Supply	Power Consumption	kVA	33	35	40	28	26

Note: Specifications are subject to change without prior notice & may vary depending upon optional accessories

- JV SERIES
- BASIC INFORMATION
- SPECIFICATIONS
- DIAGRAMS
- APPLICATIONS & SOLUTIONS
- ACCESSORIES

**SPEED POWER CURVE**

**JV 55 / JV Kraft**

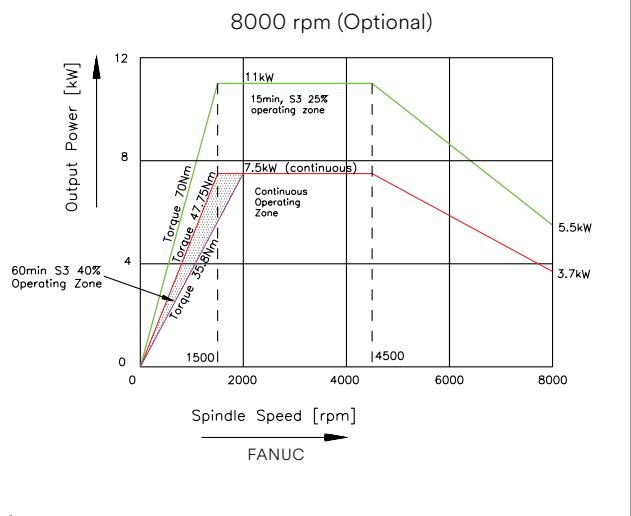
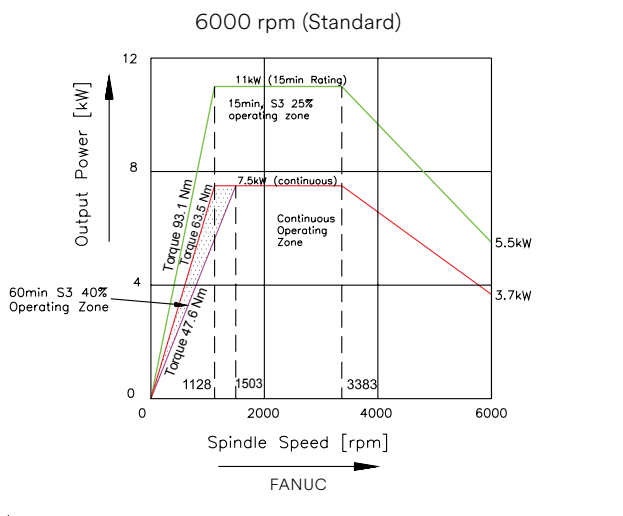

**JV 80**

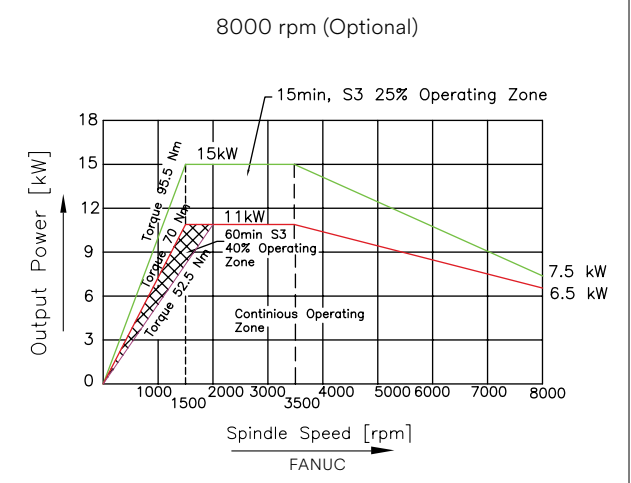
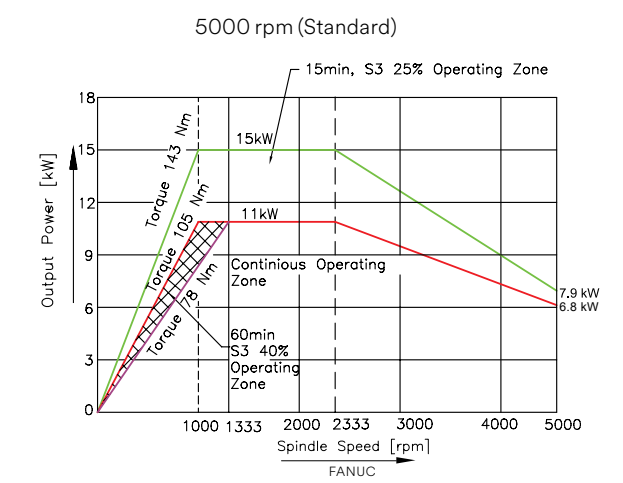

**JV 100**

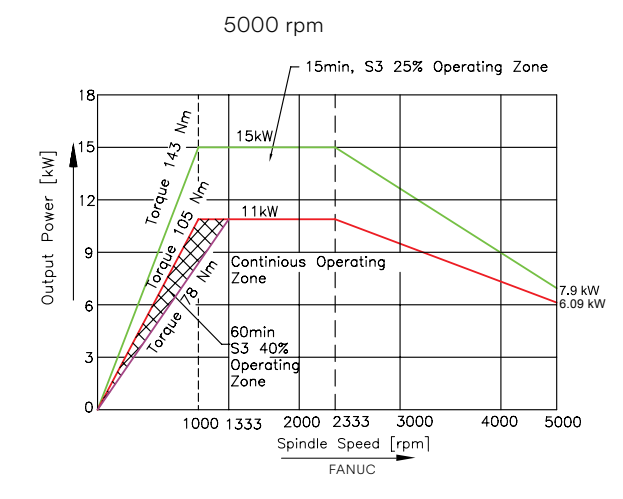

**JV 130**

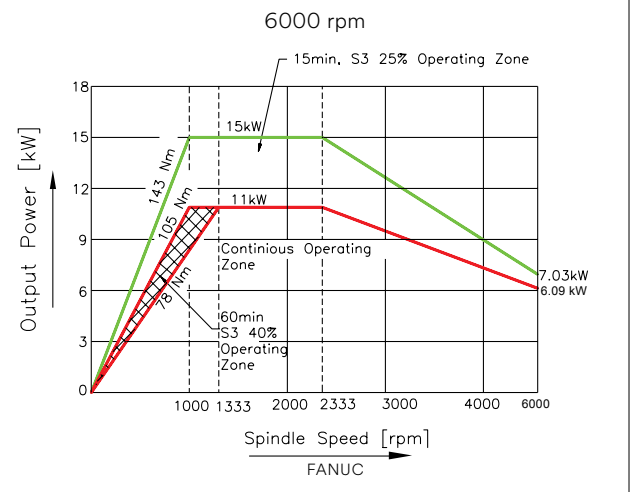

JV SERIES

BASIC INFORMATION

SPECIFICATIONS

DIAGRAMS

APPLICATIONS & SOLUTIONS

ACCESSORIES

### JV 150

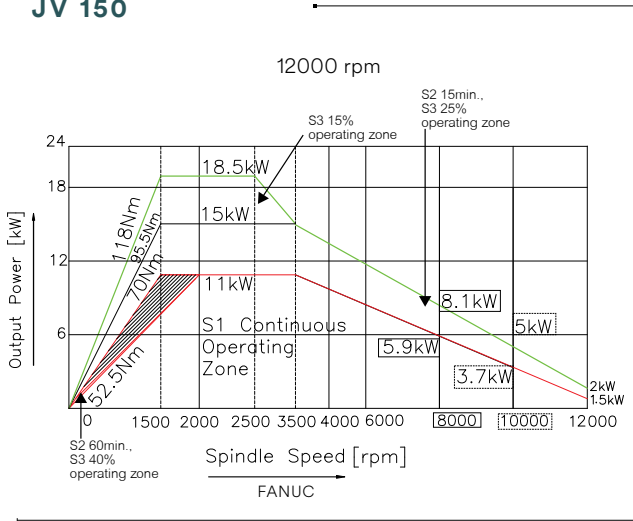

### JV 200

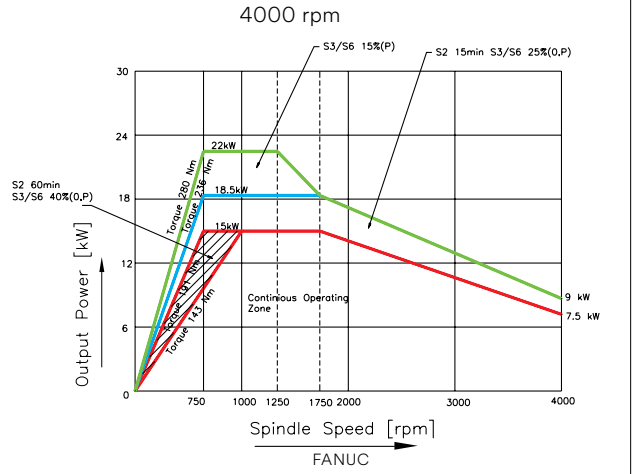

### JV 55 TWIN

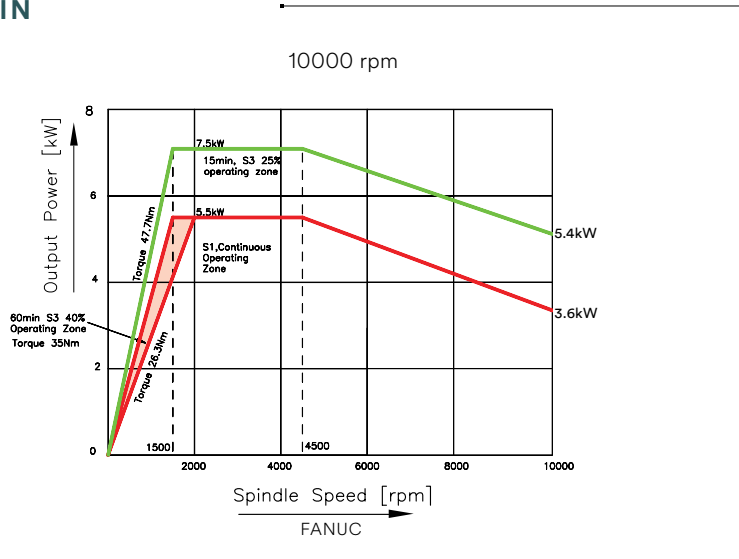

### JVM 60

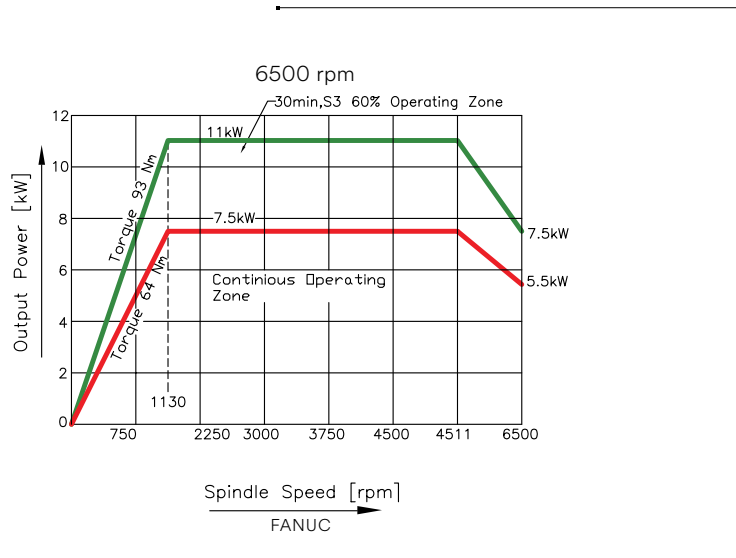

JV SERIES

BASIC INFORMATION

SPECIFICATIONS

DIAGRAMS

APPLICATIONS & SOLUTIONS

ACCESSORIES

## INTERFERENCE DIAGRAM & MOVING RANGE DIAGRAM

### JV 55

Ø 80 mm Cutter Tool

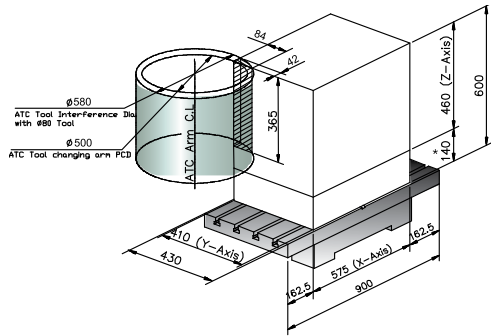

in mm

Ø 80 mm Cutter Tool

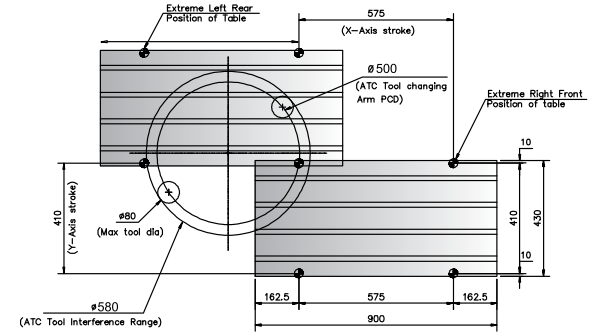

\* - 240 (100mm column)

in mm

### JV Kraft

Ø 80 mm Cutter Tool

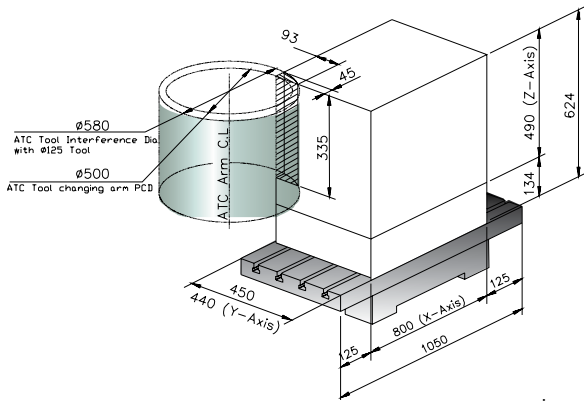

in mm

Ø 80 mm Cutter Tool

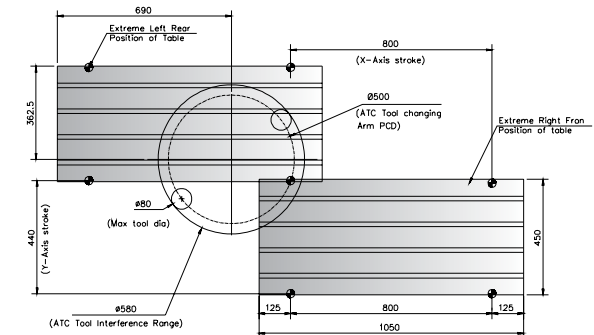

in mm

### JV 80

Ø 80 mm Cutter Tool

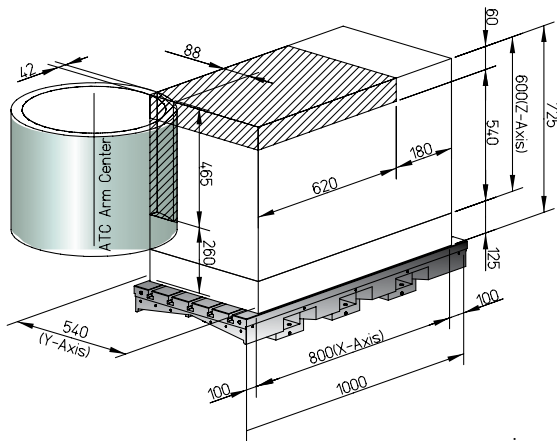

in mm

Ø 80 mm Cutter Tool

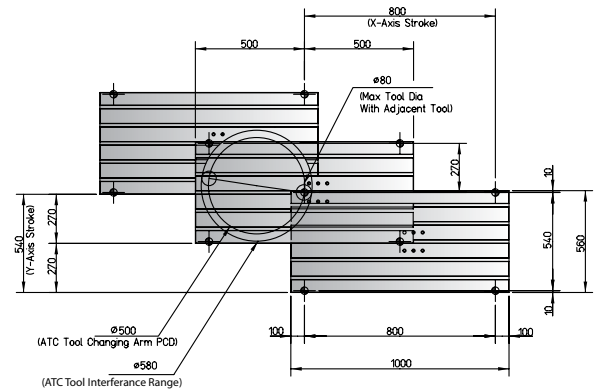

in mm

JV SERIES

BASIC INFORMATION

SPECIFICATIONS

DIAGRAMS

APPLICATIONS & SOLUTIONS

ACCESSORIES

### JV 100

Ø 80 mm Cutter Tool

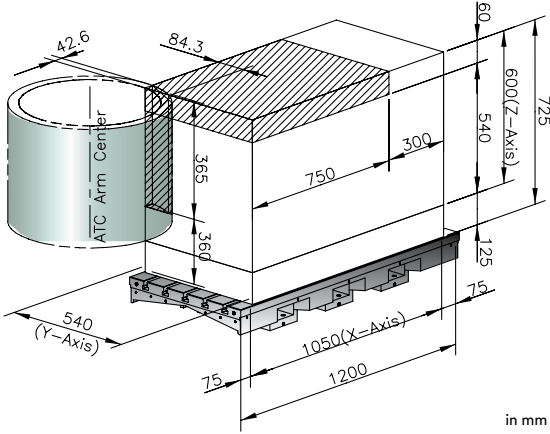

in mm

Ø 80 mm Cutter Tool

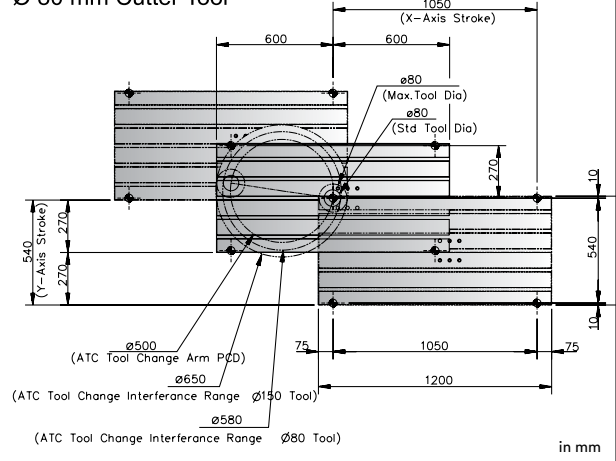

in mm

### JV 130

Ø80mm (#Ø125mm) cutter

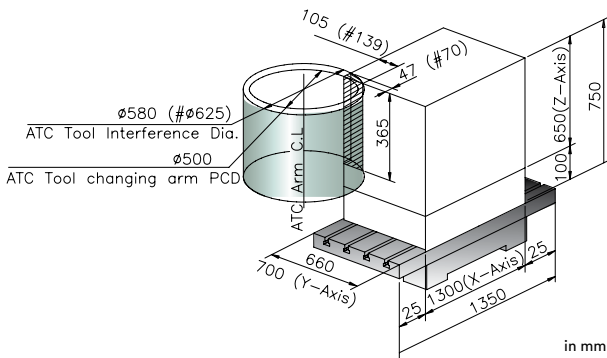

in mm

Ø80mm (#Ø125mm) cutter

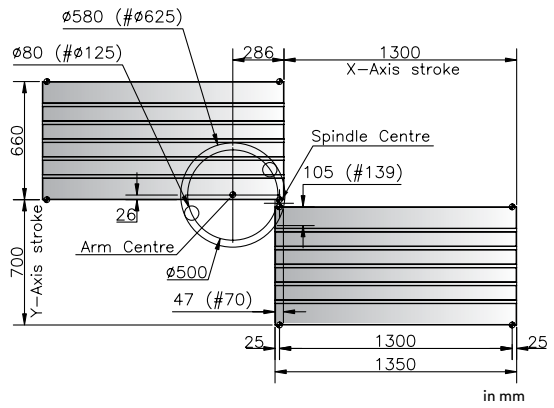

in mm

### JV 150

Ø 80 mm Cutter Tool

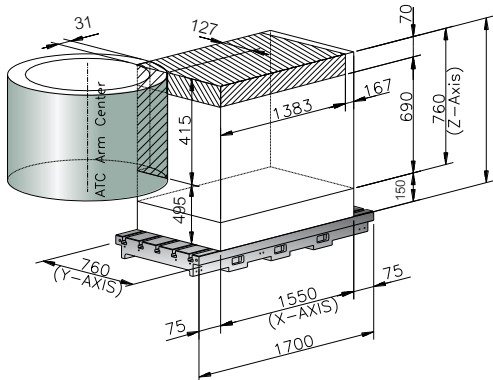

in mm

Ø 80 mm Cutter Tool

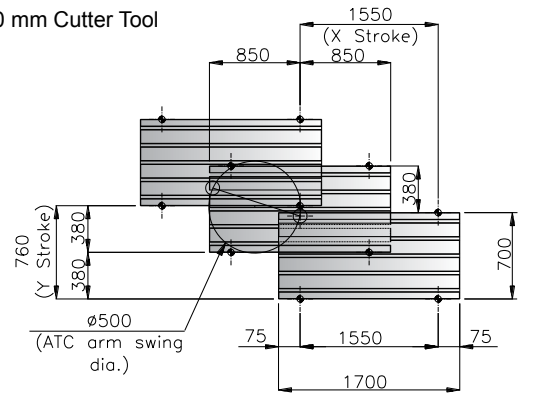

in mm

JV SERIES

BASIC INFORMATION

SPECIFICATIONS

DIAGRAMS

APPLICATIONS & SOLUTIONS

ACCESSORIES

**JV 200**

Ø130 mm cutter (# Ø200 mm)

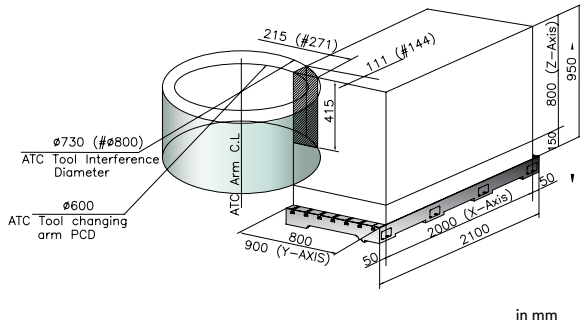

in mm

Ø130mm cutter (#Ø200mm)

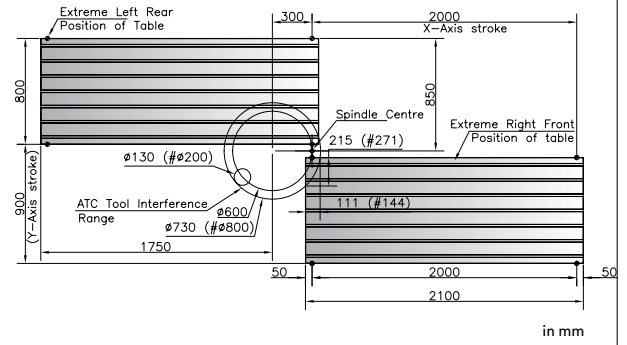

in mm

**JV 55 Twin**

Ø80mm Cutter (#Ø125mm)

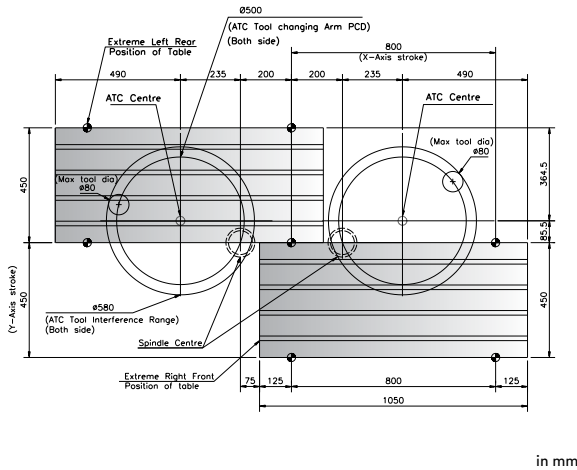

in mm

Ø80mm Cutter (#Ø125mm)

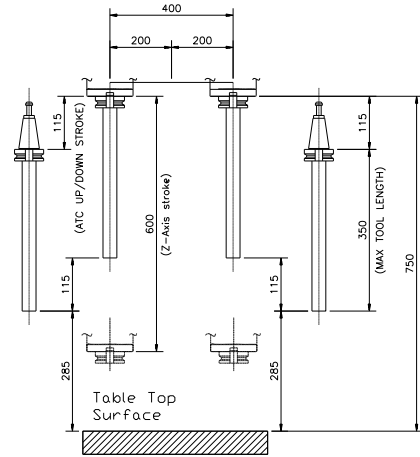

in mm

**JVM 60**

Ø 80 mm Cutter Tool

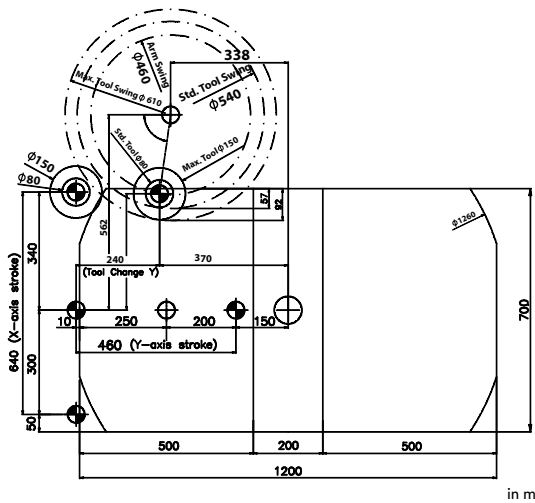

in mm

Ø 80 mm Cutter Tool

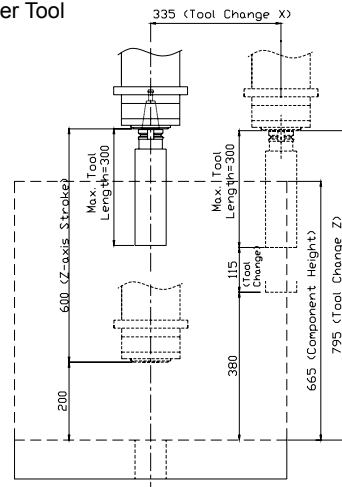

in mm

JV SERIES

BASIC INFORMATION

SPECIFICATIONS

DIAGRAMS

APPLICATIONS & SOLUTIONS

ACCESSORIES

**MACHINING PERFORMANCE : MATERIAL REMOVAL RATE (ON STEEL S45)**

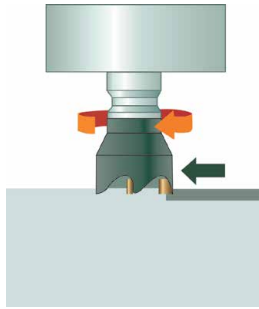

Material : Steel  
FACE MILLING

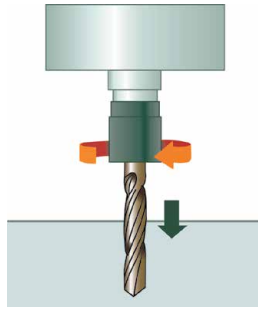

Material : Steel  
DRILLING

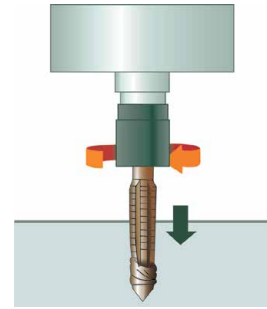

Material : Steel  
TAPPING

	Model	Unit	JV 55/ JV Kraft	JV 80	JV 100	JV 130	JV 150	JV 200	JVM 60
Milling	Spindle Power	kW	7.5 / 11	11 / 15	11 / 15	11/15.5	11/15.5	18.5/22	7.5 / 11
	Cutter Size	(mm)	Ø80 × 6z	Ø80 × 6z	Ø80 × 6z	Ø80 × 6z	Ø80 × 6z	Ø100 × 10z	Ø80 × 6z
	Speed	(rpm)	1000	1300	1000	1200	1200	800	1000
	Feed	(mm/min)	1000	1000	1000	1200	1200	1500	1000
	Width of cut	(mm)	60	60	60	60	60	80	60
	Depth of cut	(mm)	3	6	6	3.8	3.8	5	3
	Capacity	(cc/min)	180	360	360	274	274	600	180
	Spindle Load	(%)	114	90	82	97	97	110	163
Drilling	Drill Size	(mm)	Ø50 × 2z	Ø50 × 2z	Ø50 × 2z	Ø50 × 2z	Ø50 × 2z	Ø74 × 2z	Ø40 × 2z
	Speed	(rpm)	1000	1200	1000	1000	1000	650	1200
	Feed	(mm/min)	100	150	150	120	120	100	120
	Spindle Load	(%)	121	47	69	82	82	101	106
Tapping	Tap Size	(mm)	M27×3	M30×3.5	M30×3.5	M27×3	M27×3	M42×4.5	M24×3
	Speed	(rpm)	180	160	160	176	176	150	200
	Feed	(mm/min)	540	560	560	528	528	675	600
	Spindle Load	(%)	99	80	76	88	88	85	85

Note : Values shown are in test conditions, may vary depending on tools, materials and cutting parameters / conditions

JV SERIES

BASIC INFORMATION

SPECIFICATIONS

DIAGRAMS

APPLICATIONS & SOLUTIONS

ACCESSORIES

JV SERIES

BASIC INFORMATION

SPECIFICATIONS

DIAGRAMS

APPLICATIONS & SOLUTIONS

ACCESSORIES

# We Cater to ALL INDUSTRY Segments

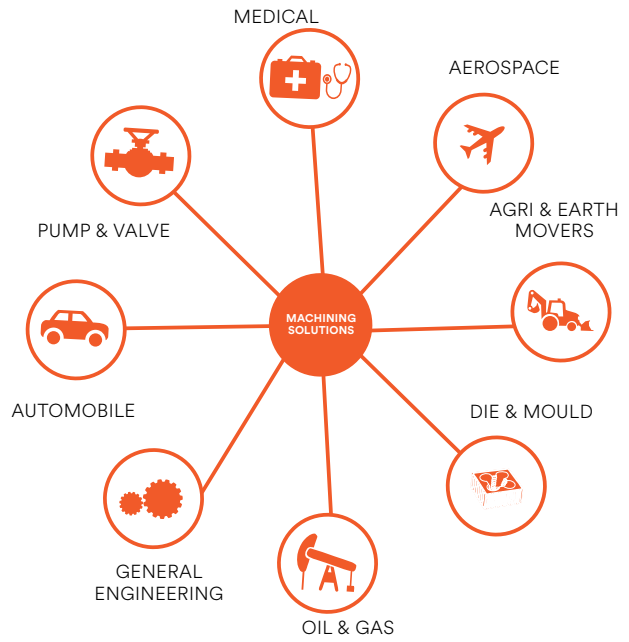

## AUTOMOBILE 2 WHEELER



Connecting Rod



Brake Disc



Axle Stub



Greeve Piston



Intermediate Shaft



CAM Shaft

## 4 WHEELER



Differential Case



Flywheel



Axle arm



Planet Carrier



Brake Drum



Impeller

## DIE MOLD



Bottle Mold



Top Finisher



Tetron Hose



Shoe mold

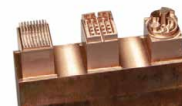

Copper Electrode



Forging Die

## PUMP & VALVE



Valve



Compressor Valve Plate



Water Pump Housing



Valve Body



Collar



Mounting Flange

**ACCESSORIES AND SPECIAL FEATURES**

**Built in Motor Spindle**

12000 RPM

15000 RPM

20000 RPM

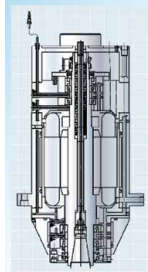
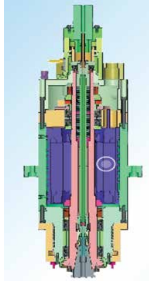
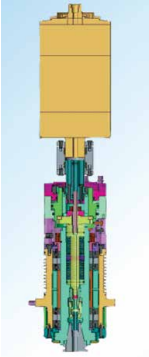

**Major Specifications**

RPM	12000	15000	20000
Mounting direction	Vertical	Vertical	Vertical
Tool Shank	BBT 40	BBT 40	BBT 40
Motor Power	17 kW	17 kW	24.8 kW
Front bearing dia	70 mm	70 mm	70 mm
Lubrication method	Grease	Grease	Grease

**ROTARY TABLE**

A

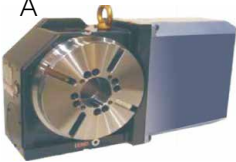

B

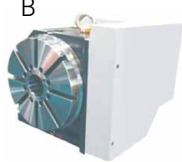

C



**CHIP CONVEYOR / OIL SKIMMER**



**PROBE**

(Tool measurement and component measurement probe)



**AUTO DOOR**

- Pneumatic type Auto door
- Operated through Program or two way switch



**COOLANT FILTERATION SYSTEM**

- Inline filtration system
- Duplex bag filter including hydrocyclone system
- Built-in filtration system (with high pressure coolant pump – imported)

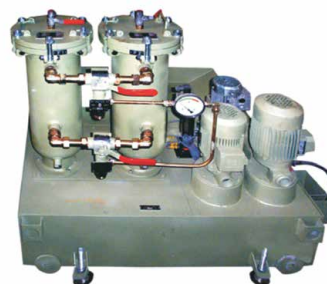

*Pictures shown are only for reference and may vary on case to case basis*

JV SERIES

BASIC INFORMATION

SPECIFICATIONS

DIAGRAMS

APPLICATIONS & SOLUTIONS

ACCESSORIES

## HIGHLY BUILD QUALITY - ENHANCED PERFORMANCE

### Spindle Natural Frequency Measurements

- To measure natural frequency of spindle system
- To measure spindle bearing and assembly condition



### Tool Clamping Force for JV Series Spindle

- To measure and control variance in tool clamping force in spindle to ensure the withstanding force generated by cutting resistance



### BALL BAR TEST



### LASER CALIBRATION



### NAS CUTTING TEST



## STANDARD FEATURES

### Electrical

- Pitch error and backlash compensation
- Graphics Display
- Machine lamp LED type
- Absolute encoder on X, Y & Z axes
- Hand held manual pulse generator
- USB Port & Ethernet connection (RJ-45)
- Process completion lamp (3 tier) LED type
- 10.4" Colour LCD Display
- LMW EOS system operating screen (Fanuc & Mitsubishi)
- Hard Probing (Fanuc)

**Mechanical**

- 20 Tools Twin Arm Type Automatic Tool Changer
- Axes drives including precision, preloaded ball screw and nut assemblies.
- C Frame design
- Automatic centralized oil lubrication system
- Slideway covers
- Full Cover
- Rigid Tapping retraction
- “T” nuts for table
- Linear motion guideways
- Swivel type operator panel
- Built-in AC for control cubicle
- Coolant flush for chip cleaning
- Coolant ring around spindle
- One set of maintenance tools
- Levelling blocks
- To measure spindle bearing and assembly condition

**OPTIONAL FEATURES**

**Electrical**

- Extra M codes
- Flash memory card
- Pen drive
- 4th & 5th axis feature
- Linear scale

**Mechanical**

- Automatic Tool Changer 24 & 30 Tools
- Auto door (Pneumatic)
- Air Drier unit
- Coolant through spindle
- Chip Conveyor – Scrapper / chain / Magnetic
- Chip trolley
- Coolant filtration system – Inline filter/ hydro cyclone bag filtration
- 100mm / 200mm column extension (No extension in Z-axis)
- Spindle oil cooler
- Rotary table

JV 55 / JV Kraft –

- Spindle Speed – 6000rpm (Fanuc/ Mitsubishi)
- Spindle Speed – 8000rpm (Siemens)

JV 80 / JV 100 -

- Spindle Speed – 5000rpm (Fanuc/Siemens)
- Spindle Speed – 8000rpm (Mitsubishi)

JV 130 -

- Spindle Speed – 6000rpm (Fanuc/Siemens)
- Spindle Speed – 8000rpm (Mitsubishi)

JV 200 -

- Spindle Speed – 4000rpm (Fanuc)

- Voltage stabilizer
- Spindle speed 10000 & 12000rpm with spindle chiller unit
- High pressure Coolant Through Spindle (12bar/ 20bar, 30bar/ 40bar/ 50 bar) with suitable filtration

- Door interlock through safety switches

- Hand held coolant gun

- Higher spindle power

JV 55 / JV Kraft –

- Spindle Speed – 4000rpm & 8000rpm (Fanuc)

JV 80 / JV 100 -

- Spindle Speed – 8000rpm (Fanuc/Siemens)

- Spindle Speed – 5000rpm (Mitsubishi)

JV 130 -

- Spindle Speed – 8000rpm (Fanuc/Siemens)

JV 150 -

- Spindle Speed – 10000rpm (Fanuc)

JV 200 -

- Spindle Speed – 5500rpm (Fanuc)



[www.lmwcnc.com](http://www.lmwcnc.com)



INDIA'S FINEST  
RANGE OF CNC MACHINES

FOLLOW US ON:



LMW CNC



INTEGRATED SOLUTIONS



**LMW LIMITED**

MACHINE TOOL DIVISION  
Arasur, COIMBATORE - 641 407, Tamil Nadu, India.  
Tel: +91 422 719 1300